

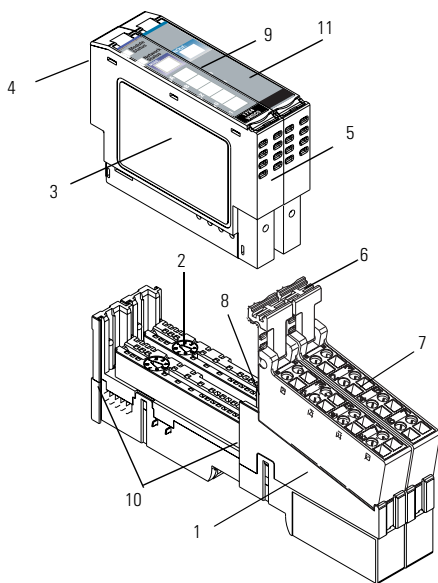

Installation Instructions

POINT I/O 5V dc Very High Speed Counter Module

(Cat. No. 1734-VHSC5 Series C)



41825

	Description		Description
1	Mounting Base ¹	7	Removable Terminal Block (RTB) ¹
2	Mechanical Keying (orange)	8	DIN Rail Locking Screw (orange)
3	Module Wiring Diagram	9	Slide-in Writable Label
4	Module Locking Mechanism	10	Interlocking Side Pieces
5	Insertable I/O Module 1	11	Insertable I/O Module 2
6	RTB Removal Handle		

¹ Wiring Base Assembly consists of item 1) mounting base, 1734-MB and item 7) removable terminal block, 1734-RT□□.

General

The VHSC is a two-module set. Module 1 houses the VHSC functionality while module 2 provides screw terminals necessary to access chassis ground (Chas Gnd) and common (C). Module 2 also connects screw 4 to 5 and screw 6 to 7 for ease of wiring power to the input device. Module 2 is not necessary for VHSC functionality; it serves only to ease customer wiring. Module 2 does not use a node address, or consume power from the PointBus. Mount module 2 adjacent to module 1.

Important User Information

Because of the variety of uses for the products described in this publication, those responsible for the application and use of these products must satisfy themselves that all necessary steps have been taken to assure that each application and use meets all performance and safety requirements, including any applicable laws, regulations, codes and standards. In no event will Allen-Bradley be responsible or liable for indirect or consequential damage resulting from the use or application of these products.

Any illustrations, charts, sample programs, and layout examples shown in this publication are intended solely for purposes of example. Since there are many variables and requirements associated with any particular installation, Allen-Bradley does not assume responsibility or liability (to include intellectual property liability) for actual use based upon the examples shown in this publication.

Allen-Bradley publication SGI-1.1, *Safety Guidelines for the Application, Installation and Maintenance of Solid-State Control* (available from your local Allen-Bradley office), describes some important differences between solid-state equipment and electromechanical devices that should be taken into consideration when applying products such as those described in this publication.

Reproduction of the contents of this copyrighted publication, in whole or part, without written permission of Rockwell Automation, is prohibited.

Throughout this publication, notes may be used to make you aware of safety considerations. The following annotations and their accompanying statements help you to identify a potential hazard, avoid a potential hazard, and recognize the consequences of a potential hazard:

WARNING

Identifies information about practices or circumstances that can cause an explosion in a hazardous environment, which may lead to personal injury or death, property damage, or economic loss.

ATTENTION

Identifies information about practices or circumstances that can lead to personal injury or death, property damage, or economic loss.

IMPORTANT

Identifies information that is critical for successful application and understanding of the product.

ATTENTION



Environment and Enclosure

This equipment is intended for use in a Pollution Degree 2 industrial environment, in overvoltage Category II applications (as defined in IEC publication 60664-1), at altitudes up to 2000 meters without derating.

This equipment is considered Group 1, Class A industrial equipment according to IEC/CISPR Publication 11. Without appropriate precautions, there may be potential difficulties ensuring electromagnetic compatibility in other environments due to conducted as well as radiated disturbance.

This equipment is supplied as "open type" equipment. It must be mounted within an enclosure that is suitably designed for those specific environmental conditions that will be present and appropriately designed to prevent personal injury resulting from accessibility to live parts. The interior of the enclosure must be accessible only by the use of a tool. Subsequent sections of this publication may contain additional information regarding specific enclosure type ratings that are required to comply with certain product safety certifications.

See NEMA Standards publication 250 and IEC publication 60529, as applicable, for explanations of the degrees of protection provided by different types of enclosure. Also, see the appropriate sections in this publication, as well as the Allen-Bradley publication 1770-4.1 ("Industrial Automation Wiring and Grounding Guidelines"), for additional installation requirements pertaining to this equipment.

ATTENTION



POINT I/O is grounded through the DIN rail to chassis ground. Use zinc plated, yellow chromated steel DIN rail to assure proper grounding. Using other DIN rail materials (e.g. aluminum, plastic, etc.) which can corrode, oxidize or are poor conductors can result in improper or intermittent platform grounding.

WARNING

When you connect or disconnect the Removable Terminal Block (RTB) with field side power applied, an electrical arc can occur. This could cause an explosion in hazardous location installations.

Be sure that power is removed or the area is nonhazardous before proceeding.

Installing the Mounting Base

To install the mounting base on the DIN rail, proceed as follows.

1. Position the mounting base vertically above the installed units (adapter, power supply or existing module).
2. Slide the mounting base down allowing the interlocking side pieces to engage the adjacent module or adapter.
3. Press firmly to seat the mounting base on the DIN rail. The mounting base will snap into place.
4. To remove the mounting base from the DIN rail, remove the module, and use a small bladed screwdriver to rotate the base locking screw to a vertical position. This releases the locking mechanism. Then lift straight up to remove.

Installing the I/O Module

The module can be installed before, or after base installation. Make sure that the mounting base is correctly keyed before installing the module into the mounting base. In addition, make sure the mounting base locking screw is positioned horizontal referenced to the base.

1. Using a bladed screwdriver, rotate the keyswitch (2) on the mounting base clockwise until the number required for the type of module being installed aligns with the notch in the base.

WARNING



When you insert or remove the module while backplane power is on, an electrical arc can occur. This could cause an explosion in hazardous location installations. Be sure that power is removed or the area is nonhazardous before proceeding.

2. Make certain the DIN rail locking screw is in the horizontal position. (You cannot insert the module if the locking mechanism is unlocked.)
3. Insert the module straight down into the mounting base and press to secure. The module will lock into place.

Installing the Removable Terminal Block (RTB)

A removable terminal block is supplied with your wiring base assembly. To remove, pull up on the RTB handle. This allows the mounting base to be removed and replaced as necessary without removing any of the wiring. To reinsert the removable terminal block, proceed as follows.

1. Insert the end opposite the handle into the base unit. This end has a curved section that engages with the wiring base.
2. Rotate the terminal block into the wiring base until it locks itself in place.
3. If an I/O module is installed, snap the RTB handle into place on the module.

WARNING



When you connect or disconnect the Removable Terminal Block (RTB) with field side power applied, an electrical arc can occur. This could cause an explosion in hazardous location installations.

Be sure that power is removed or the area is nonhazardous before proceeding.

Removing a Mounting Base

To remove a mounting base, you must remove any installed module in the base, and the module installed to the right of the base to be removed. Remove the removable terminal block (if wired).

1. Unlatch the RTB handle on the I/O module.
2. Pull on the RTB handle to remove the removable terminal block.

WARNING

When you connect or disconnect the Removable Terminal Block (RTB) with field side power applied, an electrical arc can occur. This could cause an explosion in hazardous location installations.

Be sure that power is removed or the area is nonhazardous before proceeding.

-
3. Press on the module lock on the top of the module.
 4. Pull on the I/O module to remove from the base.

WARNING

When you insert or remove the module while backplane power is on, an electrical arc can occur. This could cause an explosion in hazardous location installations. Be sure that power is removed or the area is nonhazardous before proceeding.

-
5. Use a small bladed screwdriver to rotate the orange base locking screw to a vertical position. This releases the locking mechanism.
 6. Then lift straight up to remove.

Wiring the 5V Very High Speed Counter Module

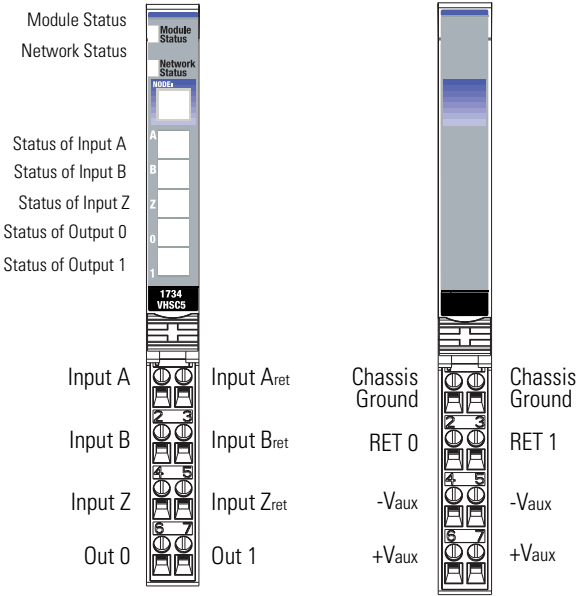

42016

Module 1		Module 2	
0 A	1 A _{ret}	0 Chas Gnd	1 Chas Gnd
2 B	3 B _{ret}	2 RET 0	3 RET 1
4 Z	5 Z _{ret}	4 -V _{aux}	5 -V _{aux}
6 Out 0	7 Out 1	6 +V _{aux}	7 +V _{aux}

Module 1 Terminations		Module 2 Terminations	
0	A	0	Chassis Ground
1	A _{ret}	1	Chassis Ground
2	B	2	Out 0 RET
3	B _{ret}	3	Out 1 RET
4	Z	4	V _{aux} -
5	Z _{ret}	5	V _{aux} -
6	Out 0	6	V _{aux} +
7	Out 1	7	V _{aux} +

Communicating with the 1734-VHSC5

I/O messages are sent to (consumed) and received from (produced) the POINT I/O modules. These messages are mapped into the processor's memory. This POINT I/O input/output module produces 6 or 10 bytes of input data (scanner Rx) (status). It consumes 2 or 4 bytes of I/O data (scanner Tx). Use parameters 23 and 24 to select assembly 101, 102 or 103 for data produced by the module. Use parameter 25 to select assembly 105, 106 or 107 for data consumed by the module. In addition, parameter 25 may be set to zero to reenable parameter 4, Active Output Assembly.

Default Data Map for the 1734-VHSC Counter Module

Message size: 6 or 10 Bytes

	15	14	13	12	11	10	09	08	07	06	05	04	03	02	01	00
Produces (scanner Rx)	Channel 0 value of present counter state (LSW)															
	Channel 0 value of present counter state (MSW)															
	P	E	N	0	F	F	O	O	0	Z	B	A	C	C	Z	0
	E	F	R		S	S	S	S		S	S	S	1	0	D	
	Requested Poll Produce Assembly															
Requested Change of State Produce Assembly																
Where: PE = Programming error EF = EEPROM fault status NR = Not ready status bit FS = Output fault status bit - bit 10 for output 0, bit 11 for output 1 OS = Output on/off status bit - bit 8 for output 0, bit 9 for output 1 ZS = Z input status BS = B input status AS = A input status C = Stored data count ZD = Zero frequency detected LSW = Least significant word MSW = Most significant word																

NOTE: When a configuration is sent to the module, it is checked for consistency before being applied. If an error is found in the configuration, the PE bit is asserted and the module retains its previous configuration. Monitor this PE bit with your user program to isolate any problems an improperly configured module may have. If the configuration is considered acceptable, the counter ASIC is disabled, counting is suspended and outputs are shut off while the ASIC is loaded with the new operational parameters.

Message size: 2 or 4 bytes

	08 thru 15	07	06	05	04	03	02	01	00
Consumes (scanner Tx)	0	0	0	0	0	0	VR	CP	CR
	0	DS	ES	OE	FO	DS	ES	OE	FO
Requested Poll Consume Assembly									
Where:VR = Value reset of stored/accumulated count CP = Counter preset CR = Counter reset DS = Diagnostic speed ES = Electronic fuse select OE = Output enable FO = Force output									

Configuring Your Very High Speed Counter Module

Parameter	Set/Get	Description	Bytes
1	Set/Get	Counter Configuration (see page 12)	1
2	Set/Get	Filter Selection (see page 13)	1
3	Set/Get	Decimal Position	1
4	Set/Get	Active Output Assembly	1
5	Set/Get	Time Base Value/PWM Period	2
6	Set/Get	Gate Interval	1
7	Set/Get	Channel Scalar (see page 13)	1
8	Set/Get	Output 0 Ties	1
9	Set/Get	Output 1 Ties	1
10	Set/Get	Channel Rollover Value	4
11	Set/Get	Channel Preset Value	4
12	Set/Get	ON Value 1	4
13	Set/Get	OFF Value 1	4
14	Set/Get	ON Value 2	4
15	Set/Get	OFF Value 2	4
16	Set/Get	ON Value 3	4
17	Set/Get	OFF Value 3	4
18	Set/Get	ON Value 4	4
19	Set/Get	OFF Value 4	4
20	Set/Get	PWM Safe State Value	2
21	Set/Get	Counter Control Safe State	1
22	Set/Get	Output Control Safe State	1
23	Set/Get	Requested Poll Produce Assembly	1
24	Set/Get	Requested COS Produce Assembly	1
25	Set/Get	Requested Poll Consume Assembly	1

Counter Configuration

07	06	05	04	03	02	01	00	
ZI	MD			CF				Counter 0
				0	0	0	0	Counter
				0	0	0	1	Encoder X1
				0	0	1	0	Encoder X2
				0	0	1	1	PWM
				0	1	0	0	Encoder X4
				0	1	0	1	Period/Rate
				0	1	1	0	Continuous/Rate
				0	1	1	1	Rate Measurement
				1	0	0	0	Pulse Generator
	0	0	0					Store Count Disabled
	0	0	1					Mode 1 - store/continue
	0	1	0					Mode 2 - store/wait/resume
	0	1	1					Mode 3 - store, reset/wait/start
	1	0	0					Mode 4 - store, reset/start
	1	0	1					Reserved
	1	1	0					Reserved
	1	1	1					Reserved
0								Z input - 0 = not inverted
1								Z input - 1 = inverted

Filter Selection

07	06	05	04	03	02	01	00	
0	ZF	BF	AF	FS				
				0	0	0	0	No Filter
				0	0	0	1	50kHz (10 μ s + 0 μ s/-1.6 μ s)
				0	0	1	0	5kHz (100 μ s + 0 μ s/-13.2 μ s)
				0	1	0	0	500Hz (1.0ms + 0ms/-125 μ s)
				1	0	0	0	50Hz (10ms + 0ms/-1.25ms)
			0					A input not filtered
			1					A input filtered
		0						B input not filtered
		1						B input filtered
	0							Z input not filtered
	1							Z input filtered

Scalar Selection

07	06	05	04	03	02	01	00	Scalar ¹
0	0	0	0	0	0	0	1	Z - F _{min} = 0.149Hz
0	0	0	0	0	0	1	0	Z/2 - F _{min} = 0.298Hz
0	0	0	0	0	1	0	0	Z/4 - F _{min} = 0.596Hz
0	0	0	0	1	0	0	0	Z/8 - F _{min} = 1.192Hz
0	0	0	1	0	0	0	0	Z/16 - F _{min} = 2.384Hz
0	0	1	0	0	0	0	0	Z/32 - F _{min} = 4.768Hz
0	1	0	0	0	0	0	0	Z/64 - F _{min} = 9.537Hz
1	0	0	0	0	0	0	0	Z/128 - F _{min} = 19.073Hz

1 Where F_{min} indicates the frequency at which the zero frequency detect is asserted due to counter overflow.

Assemblies

The Very High Speed Counter Module uses several words to communicate real time input and output data as well as non-real time module information (i.e. description, revision, etc) and configuration. The following table shows the words which can be exchanged.

Data may be read (get) or written (set) using an Explicit Message.

Instance	Services	Field	Bytes
#101 (0x65)	Get	Present Channel Data	4
		Status	2
#102 (0x66)	Get	Stored Channel Data	4
		Status	2
#103 (0x67)	Get	Present Channel Data	4
		Stored Channel Data	4
		Status	2
#104 (0x68)	Get	Programming Error Code	2
#105 (0x69)	Set/Get	Counter Control	1
		Output Control	1
#106 (0x6a)	Set/Get	PWM Value	2
#107 (0x6b)	Set/Get	PWM Value	2
		Counter Control	1
		Output Control	1
#108 (0x6c)	Set/Get	Counter Configuration	1
		Filter Selection	1
		Decimal Position	1
		Active Output Assembly	1
		Time Base or PWM Period	2
		Gate Interval	1
		Scalar	1
		Output 0 Ties	1

		Output 1 Ties	1
		Rollover Value	4
		Preset Value	4
		ON Value # 1	4
		OFF Value #1	4
		ON Value # 2	4
		OFF Value #2	4
		ON Value # 3	4
		OFF Value #3	4
		ON Value # 4	4
		OFF Value #4	4
		PWM Safe State Value	2
		Counter Control SSV	1
		Output Control SSV	1
#123 (0x7B)	Set/Get	Counter Configuration	1
		Filter Selection	1
		Decimal Position	1
		Active Output Assembly	1
		Time Base or PWM Period	2
		Gate Interval	1
		Scalar	1
		Output 0 Ties	1
		Output 1 Ties	1
		Alignment (reserved = 0)	2
		Rollover Value	4
		Preset Value	4
		ON Value # 1	4
		OFF Value #1	4

16 POINT I/O 5V dc Very High Speed Counter Module

		ON Value # 2	4
		OFF Value #2	4
		ON Value # 3	4
		OFF Value #3	4
		ON Value # 4	4
		OFF Value #4	4
		PWM Safe State Value	2
		Counter Control SSV	1

Troubleshooting with the Indicators

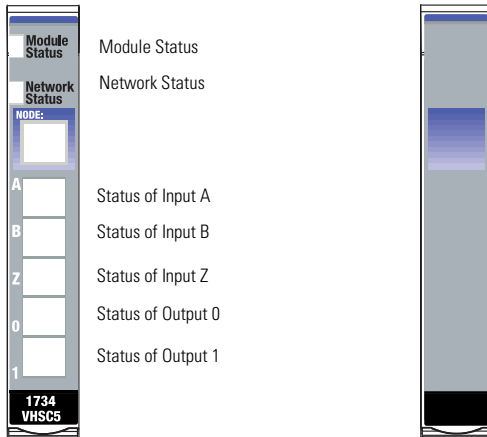



Indication	Probable Cause
Module Status	
Off	No power applied to device
Green	Device operating normally
Flashing Green	Device needs commissioning due to configuration missing, incomplete or incorrect.
Flashing Red	Recoverable fault.
Red	Unrecoverable fault may require device replacement
Flashing Red/Green	Device is in self-test

Indication	Probable Cause
Network Status	
Off	Device is not on-line - Device has not completed dup_MAC_id test. - Device not powered - check module status indicator
Flashing Green	Device is on-line but has no connections in the established state.
Green	Device on-line and has connections in the established state.
Flashing Red	One or more I/O connections in timed-out state
Red	Critical link failure - failed communication device. Device detected error that prevents it communicating on the network.
Flashing Red/Green	Communication faulted device - the device has detected a network access error and is in communication faulted state. Device has received and accepted an Identify Communication Faulted Request - long protocol message.

Indication	Probable Cause
Input Status	
Off	Input inactive
Yellow	Input is active and under control
Flashing Yellow	Input is toggling on and off

Indication	Probable Cause
Output Status	
Off	Output inactive
Yellow	Output is active and under control
Flashing Yellow	Output is toggling
Flashing Red	Output is faulted (open, short or no output power)
Flashing Red/Yellow	Output is toggling and faulted (possibly open)

Safety Approvals

<p>The following information applies when operating this equipment in hazardous locations:</p>		<p>Informations sur l'utilisation de cet équipement en environnements dangereux:</p>	
<p>Products marked "CL I, DIV 2, GP A, B, C, D" are suitable for use in Class I Division 2 Groups A, B, C, D, Hazardous Locations and nonhazardous locations only. Each product is supplied with markings on the rating nameplate indicating the hazardous location temperature code. When combining products within a system, the most adverse temperature code (lowest "T" number) may be used to help determine the overall temperature code of the system. Combinations of equipment in your system are subject to investigation by the local Authority Having Jurisdiction at the time of installation.</p>		<p>Les produits marqués "CL I, DIV 2, GP A, B, C, D" ne conviennent qu'à une utilisation en environnements de Classe I Division 2 Groupes A, B, C, D dangereux et non dangereux. Chaque produit est livré avec des marquages sur sa plaque d'identification qui indiquent le code de température pour les environnements dangereux. Lorsque plusieurs produits sont combinés dans un système, le code de température le plus défavorable (code de température le plus faible) peut être utilisé pour déterminer le code de température global du système. Les combinaisons d'équipements dans le système sont sujettes à inspection par les autorités locales qualifiées au moment de l'installation.</p>	
<p>WARNING</p> 	<p>EXPLOSION HAZARD -</p> <ul style="list-style-type: none"> • Do not disconnect equipment unless power has been removed or the area is known to be nonhazardous. • Do not disconnect connections to this equipment unless power has been removed or the area is known to be nonhazardous. Secure any external connections that mate to this equipment by using screws, sliding latches, threaded connectors, or other means provided with this product. • Substitution of components may impair suitability for Class I, Division 2. • If this product contains batteries, they must only be changed in an area known to be nonhazardous. 	<p>AVERTISSEMENT</p> 	<p>RISQUE D'EXPLOSION –</p> <ul style="list-style-type: none"> • Couper le courant ou s'assurer que l'environnement est classé non dangereux avant de débrancher l'équipement. • Couper le courant ou s'assurer que l'environnement est classé non dangereux avant de débrancher les connecteurs. Fixer tous les connecteurs externes reliés à cet équipement à l'aide de vis, loquets coulissants, connecteurs filetés ou autres moyens fournis avec ce produit. • La substitution de composants peut rendre cet équipement inadapté à une utilisation en environnement de Classe 1, Division 2. • S'assurer que l'environnement est classé non dangereux avant de changer les piles.

Specifications

Specifications - 1734-VHSC5/C Very High Speed Counter Module

Input Specifications

Number of Inputs	1 - 1 group of A/Areturn, B/Breturn and Z/Zreturn
Input Voltage	5V dc
Input Current	19.1mA @ 5V dc 25.7mA @ 6V dc
Input OFF-State Current	$\leq 0.250\text{mA}$ max
Input OFF-State Voltage	$\leq 1.25\text{V}$ (dc)
Input ON-State Current	$\geq 5\text{mA}$
Input ON-State Voltage	$\geq 2.6\text{V}$ dc
Maximum ON-State Voltage	$\pm 6\text{V}$
Input Filter Selections	Off 10 μs 100 μs 1.0ms 10.0ms
Maximum Input Frequency	1.0MHz counter and encoder X1 configurations 500kHz encoder X2 configuration (no filter) 250kHz encoder X4 configuration (no filter)

Output Specifications

Number of Outputs	1 isolated group of 2 capable of 0.5A @ 24V dc
Output Control	Outputs can be tied to any of 4 compare windows
Output Supply Voltage Range	10-28.8V dc
OFF-State Leakage Current	$\leq 0.5\text{mA}$
ON-State Voltage Drop	$\leq 0.3\text{V}$ dc @ 0.5A
ON-State Current	0.5A maximum
Short Circuit Current	6A - Outputs are short circuit protected and either cycle until the fault is corrected, or latch off (depending upon programming) Short circuit detected when output is turned on.
Open Wire Detection	Open wire detected when output is turned off
Delay Time OFF to ON ON to OFF	25 μs (load dependent) 150 μs (load dependent)

General Specifications

Module Location	1734-TB, -TBS, -TB3, -TB3S wiring base assembly
Keyswitch Position	2
Pointbus Current	180mA maximum
Power Dissipation	1.5W maximum @ rated load
Thermal Dissipation	5.1 BTU/hr maximum @ rated load
Isolation Voltage (minimum)	Qualification tested to 1100V dc for 1 minute between: Module 1 System side Chassis ground A/B/Z inputs 00/01 and user power supply Module 2 System side Chassis ground Vaux ± User power supply common
External dc Power (does not represent power required for outputs)	No additional external power required to power module.
Field Power Bus	24V dc nominal; range 10-28.8V dc
Mass	1.15 oz/32.60 grams
Environmental Conditions	
Operational Temperature	IEC 60068-2-1 (Test Ad, Operating Cold), IEC 60068-2-2 (Test Bd, Operating Dry Heat), IEC 60068-2-14 (Test Nb, Operating Thermal Shock): -20 to 55°C (-4 to 131°F)
Storage Temperature	IEC 60068-2-1 (Test Ab, Unpackaged Nonoperating Cold), IEC 60068-2-2 (Test Bb, Unpackaged Nonoperating Dry Heat), IEC 60068-2-14 (Test Na, Unpackaged Nonoperating Thermal Shock): -40 to 85°C (-40 to 185°F)
Relative Humidity	IEC 60068-2-30 (Test Db, Unpackaged Nonoperating Damp Heat): 5 to 95% noncondensing
Shock Operating Non-operating	IEC 60068-2-27 (Test Ea, Unpackaged Shock) 30g peak acceleration 50g peak acceleration
Vibration	IEC 60068-2-6, (Test Fc, Operating) Tested 5g @ 10-500Hz

ESD Immunity	IEC 61000-4-2: 6kV contact discharges 8kV air discharges																
Radiated RF Immunity	IEC 61000-4-3: 10V/m with 1kHz sine-wave 80%AM from 30MHz to 1000MHz 10V/m with 200Hz 50% pulse 100%AM at 900MHz																
EFT/B Immunity	IEC 61000-4-4: ±4kV at 2.5kHz on power ports ±2kV at 2.5kHz on signal ports																
Surge Transient Immunity	IEC 61000-4-5: ±1kV line-line(DM) and ±2kV line-earth(CM) on signal ports ±1kV line-line(DM) and ±2kV line-earth(CM) on power ports																
Conducted RF Immunity	IEC 61000-4-6: 10Vrms with 1kHz sine-wave 80%AM from 150kHz to 80MHz																
Emissions	CISPR 11 Group 1, Class A																
Enclosure Type Rating	None (open-style)																
Conductors Wire Size	14 AWG (2.5mm ²) - 22 AWG (0.25mm ²) solid or stranded copper wire rated at 75°C or greater 3/64 inch (1.2mm) insulation maximum																
Category	2 ²																
Field Wiring Terminations	<p>Module 1</p> <table> <tr> <td>0 - A</td> <td>1 - Aret</td> </tr> <tr> <td>2 - B</td> <td>3 - Bret</td> </tr> <tr> <td>4 - Z</td> <td>5 - Zret</td> </tr> <tr> <td>6 - Output 0</td> <td>7 - Output 1</td> </tr> </table> <p>Module 2</p> <table> <tr> <td>0 - Chassis ground</td> <td>1 - Chassis ground</td> </tr> <tr> <td>2 - Return 0</td> <td>3 - Return 1</td> </tr> <tr> <td>4 - -V</td> <td>5 - -V</td> </tr> <tr> <td>6 - +V</td> <td>7 - +V</td> </tr> </table>	0 - A	1 - Aret	2 - B	3 - Bret	4 - Z	5 - Zret	6 - Output 0	7 - Output 1	0 - Chassis ground	1 - Chassis ground	2 - Return 0	3 - Return 1	4 - -V	5 - -V	6 - +V	7 - +V
0 - A	1 - Aret																
2 - B	3 - Bret																
4 - Z	5 - Zret																
6 - Output 0	7 - Output 1																
0 - Chassis ground	1 - Chassis ground																
2 - Return 0	3 - Return 1																
4 - -V	5 - -V																
6 - +V	7 - +V																
Terminal Base Screw Torque	7 pound-inches (0.6Nm)																
Dimensions	Inches (Millimeters)																
	2.21H x 0.47W x 2.97L (56.0H x 12.0W x 75.5L)																

<p>Agency Certification (when product is marked)</p>	<p>C-UL-US - UL Listed Industrial Control Equipment, certified for US and Canada C-UL-US - UL Listed for Class I, Division 2, Groups A, B, C and D Hazardous locations, certified for US and Canada CE³ - European Union 89/336/EEC EMC Directive, compliant with: EN 50081-2; Industrial Emissions EN 50082-2; Industrial Immunity EN 61326; Meas./Control/Lab., Industrial Requirements EN 61000-6-2; Industrial Immunity C-Tick³ - Australian Radiocommunications Act compliant with AS/NZS 2064, Industrial Emissions</p>
<p>User Manual</p>	<p>Publication 1734-UM003□-EN-P</p>

- 1 Off/on delay is time from a valid output “on” signal to output energization. On/off delay is time from a valid output “off” signal to output deenergization.
- 2 Use this conductor category information for planning conductor routing as described in publication 1770-4.1, “Industrial Automation Wiring and Grounding Guidelines.”
- 3 See the Product Certification link at www.ab.com for Declaration of Conformity, Certificates, and other certification details.

Reach us now at www.rockwellautomation.com

Wherever you need us, Rockwell Automation brings together leading brands in industrial automation including Allen-Bradley controls, Reliance Electric power transmission products, Dodge mechanical power transmission components, and Rockwell Software. Rockwell Automation's unique, flexible approach to helping customers achieve a competitive advantage is supported by thousands of authorized partners, distributors and system integrators around the world.

Americas Headquarters, 1201 South Second Street, Milwaukee, WI 53204, USA, Tel: (1) 414 382-2000, Fax: (1) 414 382-4444
European Headquarters SA/IV, avenue Hermann Dieroux, 46, 1160 Brussels, Belgium, Tel: (32) 2 663 06 00, Fax: (32) 2 663 06 40
Asia Pacific Headquarters, 27/F Citicorp Centre, 16 Whitfield Road, Causeway Bay, Hong Kong, Tel: (852) 2987 4788, Fax: (852) 2508 1846



**Rockwell
Automation**

Publication 1734-IN004D-EN-P - February 2002

PN 957657-47

© 2002 Rockwell International Corporation. Printed in USA