

# DigitroniK Line SDC20/21 Digital Indicating Controller User's Manual



Yamatake Corporation

---

---

## RESTRICTIONS ON USE

---

---

This product has been designed, developed and manufactured for general-purpose application in machinery and equipment.

Accordingly, when used in applications outlined below, special care should be taken to implement a fail-safe and/or redundant design concept as well as a periodic maintenance program.

- Safety devices for plant worker protection
- Start/stop control devices for transportation and material handling machines
- Aeronautical/aerospace machines
- Control devices for nuclear reactors

Never use this product in applications where human safety may be put at risk.

## REQUEST

---

---

Ensure that this User's Manual is handed over to the user before the product is used.

Copying or duplicating this User's Manual in part or in whole is forbidden. The information and specifications in this User's Manual are subject to change without notice.

Considerable effort has been made to ensure that this User's Manual is free from inaccuracies and omissions.

If you should find any inaccuracies or omissions, please contact Yamatake Corporation.

In no event is Yamatake Corporation liable to anyone for any indirect, special or consequential damages as a result of using this product.

---

---

©1993 Yamatake Corporation ALL RIGHTS RESERVED

The above is a registered trademark of Yamatake Corporation.

Other company names and product names listed in this manual are registered trademarks or trademarks of respective companies.

## SAFETY REQUIREMENTS



To reduce risk of electric shock which could cause personal injury, follow all safety notices in this documentation.



This symbol warns the user of a potential shock hazard where hazardous live voltages may be accessible.

- \* If the equipment is used in a manner not specified by the manufacturer, the protection provided by the equipment must be impaired.
- \* Do not replace any component (or part) not explicitly specified as replaceable by your supplier.
- \* All wiring must be in accordance with local norms and carried out by authorized experienced personnel.
- \* The ground terminal must be connected before any other wiring (and disconnect last).
- \* A switch in the main supply is required near the equipment.
- \* In case of AC power supply models, mains power supply wiring requires a (T) 0.5 A, 250 V fuse(s).

Installation category:       Category II (IEC664-1, EN61010-1)

Specification of common mode voltage: The common mode voltages of all I/O except for main supply and relay outputs are less than 30V rms, 42.4 V peak and 60V dc.

### EQUIPMENT RATINGS

Supply voltage	85 to 264 Vac
Frequency	50/60 Hz
Power or current ratings	18 VA maximum

### EQUIPMENT CONDITIONS

Do not operate the instrument in the presence of flammable liquids or vapors. Operation of any electrical instrument in such an environment constitutes a safety hazard.

Temperature	0 to 50°C
Humidity	10 to 90% RH
Vibration	Frequency 10 to 60 Hz Acceleration 2 m/s <sup>2</sup> maximum

### EQUIPMENT INSTALLATION

The controller must be mounted into a panel to limit operator access to the rear terminals.

# Safety Precautions

This manual describes how to use this product. Before using this product, thoroughly read and understand the descriptions in this manual to ensure correct use.

After you have read this manual, store the manual a safe place nearby so that it can be referred whenever need.



## WARNING

- **Before connecting or disconnecting wiring to or from this product, be sure to turn the mains power supply OFF. Inadvertently touching terminals or other electrically live parts might cause electric shock.**
- **Before connecting this product to the measurement target or external control circuits, make sure that it is connected to an earth. Failure to do so might cause electric shock or fire.**



## CAUTION

- Wire this product properly in accordance with predetermined wiring standards, instruction described in this manual and generally accepted wiring methods. Failure to do so might result in electric shock, fire or malfunction.
- Use this product only within the recommended operating conditions (temperature, humidity, voltage, vibration, shock, atmosphere, etc.) described in the specifications.
- Do not cover the ventilation holes on this product. Doing so might result in fire or malfunction.
- Do not disassemble this product, or touch parts inside. Doing so might result in electric shock or malfunction.
- Some parts in this product become hot while the power is turned ON or are hot immediately after the power is turned OFF. Do not touch these parts. Doing so might result in burns.
- Do not operate the operation keys on this product with the top of a propelling pencil or other sharp-tipper object. Doing so might result in malfunction.

# Contents

---

## Safety Precautions

<b>Chapter 1</b>	<b>NAMES AND FUNCTIONS OF COMPONENT PARTS.....</b>	<b>1-1</b>
<b>Chapter 2</b>	<b>INSTALLATION.....</b>	<b>2-1</b>
2-1	SDC20 External Dimensions.....	2-1
2-2	SDC20 Panel Cutout Sizes.....	2-2
2-3	SDC21 External Dimensions.....	2-3
2-4	SDC21 Panel Cutout Dimensions.....	2-4
2-5	Mounting.....	2-5
	■ Location of mounting.....	2-5
	■ Mounting method.....	2-5
2-6	External Dimensions of Current Transformer.....	2-6
<b>Chapter 3</b>	<b>WIRING.....</b>	<b>3-1</b>
3-1	Cables.....	3-2
3-2	Terminal Connections.....	3-3
3-3	Terminal Arrangement.....	3-4
3-4	Power Supply Connections.....	3-4
3-5	Grounding.....	3-5
3-6	Input Connection.....	3-5
3-7	Output Connection.....	3-6
3-8	Connection of Remote Switch(option).....	3-7
3-9	Connection of Current Transformer (CT, option).....	3-7
3-10	Communication Connection.....	3-8
3-11	Wiring Precautions.....	3-10
3-12	Countermeasures Against Noise.....	3-10
<b>Chapter 4</b>	<b>SETTING THE SETUP ITEMS.....</b>	<b>4-1</b>
4-1	Setup Operation.....	4-1
4-2	Setup Table.....	4-2
4-3	Basic Operation for Setup.....	4-3
4-4	Description on the Setup Items.....	4-5
<b>Chapter 5</b>	<b>SETTING OF PARAMETERS.....</b>	<b>5-1</b>
5-1	Parameters Table.....	5-1
5-2	Basic Parameter Operation.....	5-2
5-3	Assigning a Parameter to the (PARA) Key.....	5-3
5-4	Resetting a Parameter Assigned to the (PARA) Key.....	5-4
5-5	Operation of Parameters Assigned.....	5-5
5-6	Description on Parameters.....	5-6
<b>Chapter 6</b>	<b>OPERATION.....</b>	<b>6-1</b>
6-1	Turning on the Power Supply.....	6-2
6-2	Indicating a PV.....	6-4
6-3	Indicating an SP.....	6-4
6-4	Indicating the Output Value.....	6-5
6-5	Indicating the Heater Current Value (optional).....	6-6
6-6	Changing an SP (with single SP).....	6-7
6-7	Changing an SP (with multi SP).....	6-8
6-8	Selecting the SP of Multi SP.....	6-9
6-9	Changing the Set Value of Event (optional).....	6-10

---

6-10	Changing the Set Value of PV Bias .....	6-11
6-11	Changing Various Parameters .....	6-12

**Chapter 7 TROUBLESHOOTING ..... 7-1**

7-1	Alarms Indication .....	7-1
7-2	Alarm Codes Table .....	7-1
7-3	Heater Breakage Alarm .....	7-2
7-4	Other Troubles .....	7-3

**Chapter 8 SPECIFICATIONS ..... 8-1**

8-1	Model Number Configuration .....	8-1
8-2	Specifications .....	8-4

**Chapter 9 MAINTENANCE ..... 9-1**

**APPENDICES**

Setup Table .....	Appendix-2
Parameter Table .....	Appendix-4
Input Ranges Table .....	Appendix-5
Alarm Table .....	Appendix-6
SDC 20/21 Setting Work Sheets .....	Appendix-7
Description on Terms and Abbreviations .....	Appendix-12

# Chapter 1 NAMES AND FUNCTIONS OF COMPONENT PARTS

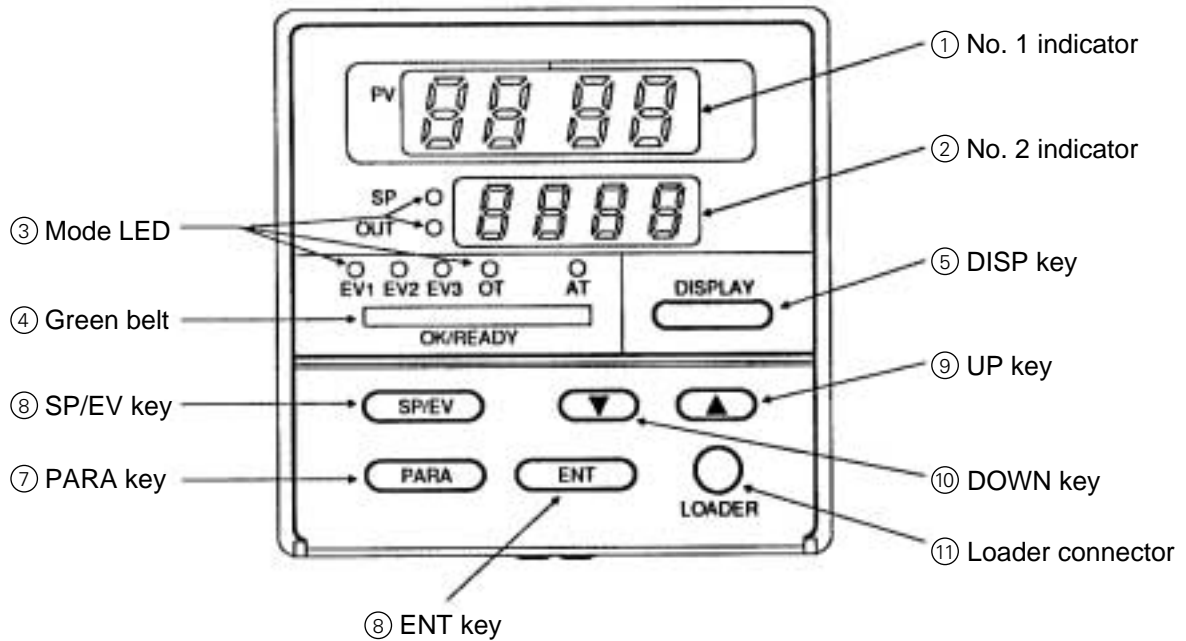

## Names and Functions of Component parts on the Front Panel

SDC21 (96 mm x 96 mm size)

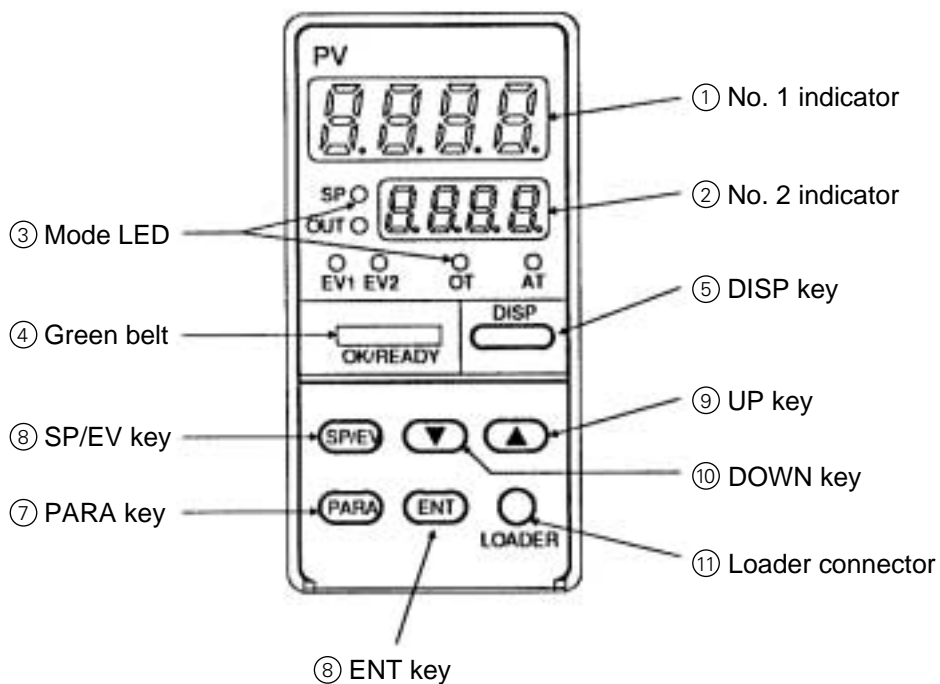

SDC20 (48 mm x 96 mm size)



- ① No.1 indicator: Indicates a PV(Process Variable) and can also indicate the contents of parameters, etc.
- ② No.2 indicator: Indicates an SP (Set Point) and can also indicate the numerics of parameters, etc.
- ③ Model LED: Lights according to the operation of this instrument.  
 SP/OUT: Indicates what is expressed in the No.2 indicator .  
 EV1 to EV3: Lights when an event output is turned on.  
 OT: Relay output (OD). Lights when the relay is turned on, and goes out when the relay is turned off.  
 Voltage output (6D). Flashes according to output duty.  
 Current output (5G). Lights normally.  
 AT: Flashes during auto tuning operation.  
 Lights during overshoot suppression learning.  
 Green belt: Lights within the range set in setup item C23.  
 Flashes when the remote switch is turned on.
- ④ Green belt: Lights when a difference (deviation) between PV (Process Variable) and SP (Set Point) is within a predetermined range. Flashes under the READY condition.
- ⑤ DISP key: Set the display to basic indication status.  
 Indicates a PV on the No.1 indicator and an SP on the No.2 indicator. Determines the contents of the No.2 indicator.
- ⑥ SP/EV key: Changes an SP (Set Point) or a set value of an event (optional).
- ⑦ PARA key: Changes parameters.
- ⑧ ENT key: Defines a changed numeric.
- ⑨ UP  key: Increases numerics.
- ⑩ Down  key: Decreases numerics.
- ⑪ Loader connector: This connector is used to connect the Handy Loader (optional).

# Chapter 2 INSTALLATION

## 2-1 SDC20 External Dimensions

**SDC20 (48 x 96)**

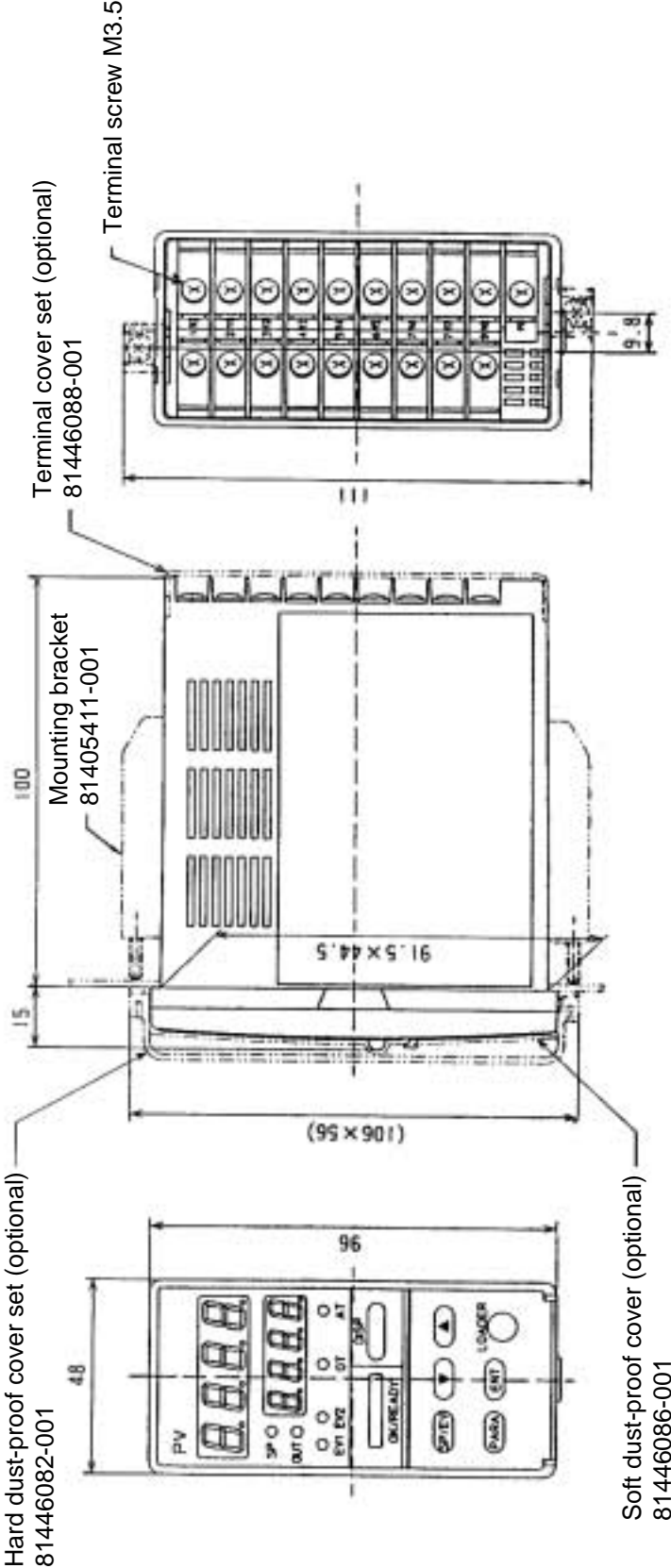

Unit: mm

## 2-2 SDC20 Panel Cutout Sizes

### SDC20 (48 x 96)

Panel cutout size for closed mounting  
(Recommendable sizes)

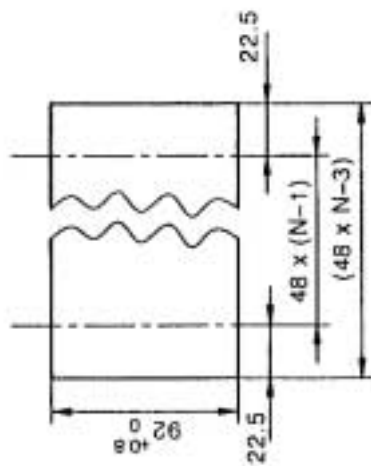

N: No. of mounting units

Panel cutout size (Recommended) with  
vertical and horizontal mounting

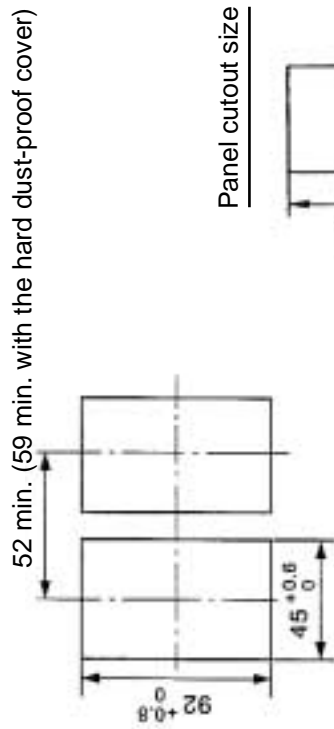

52 min. (59 min. with the hard dust-proof cover)

Panel cutout size

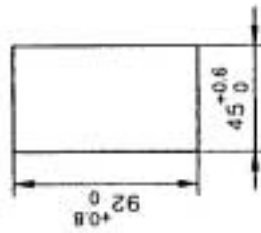

Unit: mm

### ⚠ HANDLING PRECAUTIONS

- When gang-mounting, make sure that the controller is used in an operating temperature of 40°C or below.

### 2-3 SDC21 External Dimensions

SDC21 (96 x 96)

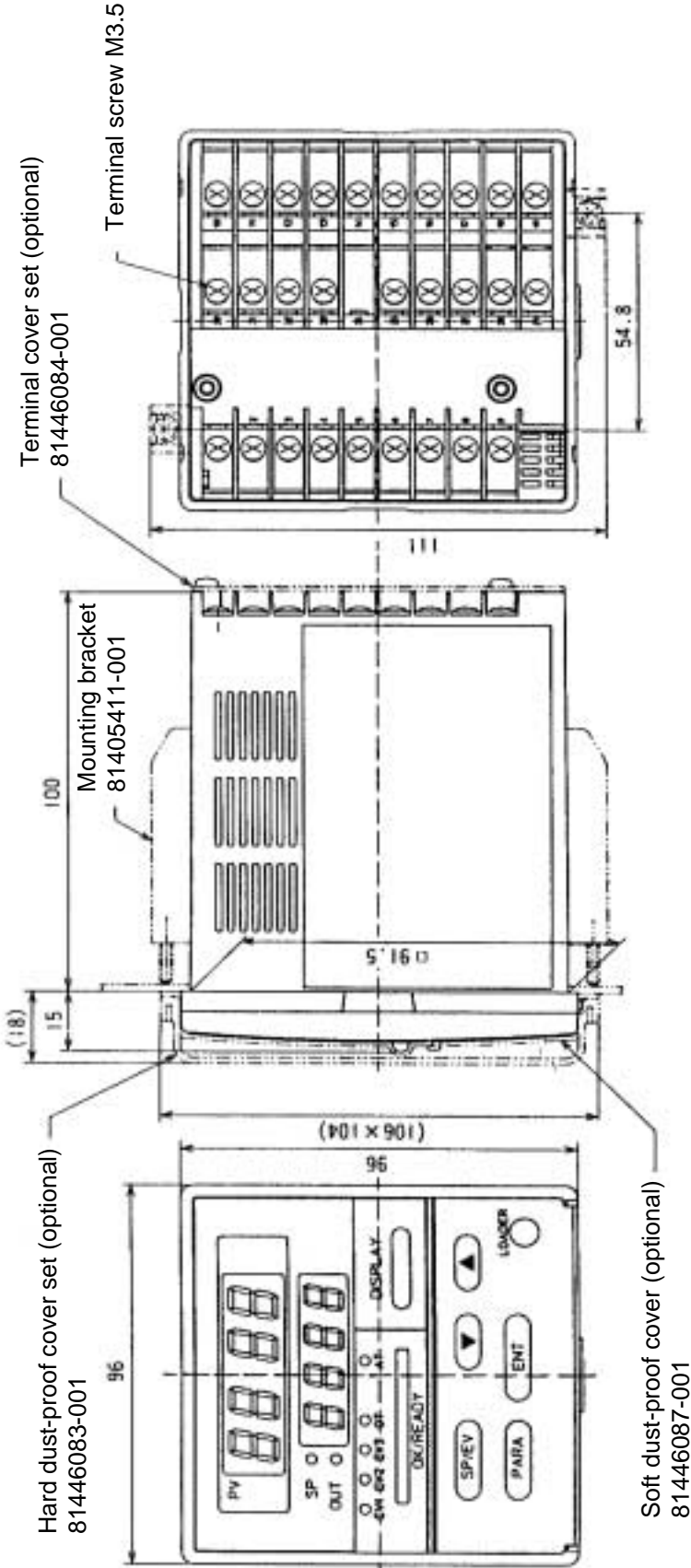

Unit: mm

## 2-4 SDC21 Panel Cutout Dimensions

### SDC21 (96 x 96)

Panel cutout size for closed mounting  
(Recommended sizes)

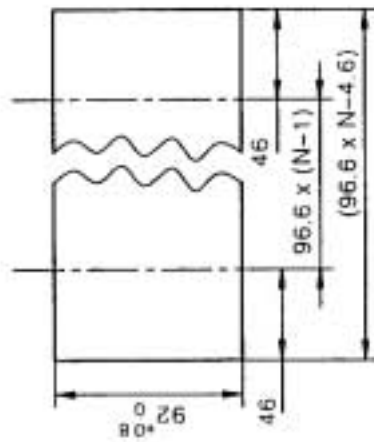

N: No. of mounting units

Panel cutout size (Recommended) with  
vertical and horizontal mounting

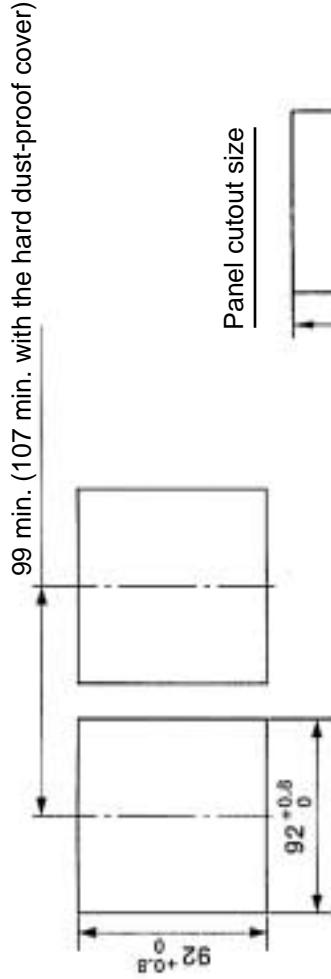

Panel cutout size

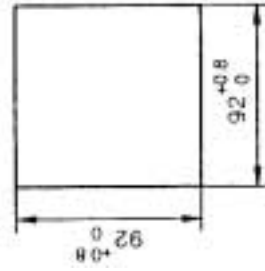

Unit: mm

### ! HANDLING PRECAUTIONS

- When gang-mounting, make sure that the controller is used in an operating temperature of 40°C or below.

## 2-5 Mounting

### ■ Location of mounting

Mount the instrument at a location which satisfies the following conditions.

- Mount the instrument in locations: Not subject to high or low temperatures, or high or low humidity.
- Free of corrosive gas (sulfide gas, etc.)
- Free of dust particles, soot, or the like.
- Not exposed to direct sunlight or the weather.
- Free of mechanical vibrations.
- Do not mount instrument near a high-tension line, a welder, or electrical noise generating sources.
- Make sure the instrument is more than 15 meters from a boiler or other high-voltage ignition devices.
- The location should not be subject to a strong magnetic field.
- The location should not be subject to inflammable liquids or gases.

### ■ Mounting method

- Mount the instrument so that it does not tilt horizontally more than  $10^\circ$  (+ or -).
- Use a steel panel with a plate thickness of more than 2 mm.
- Fix the upper and lower panels of the instrument securely by using the attached mounting bracket.

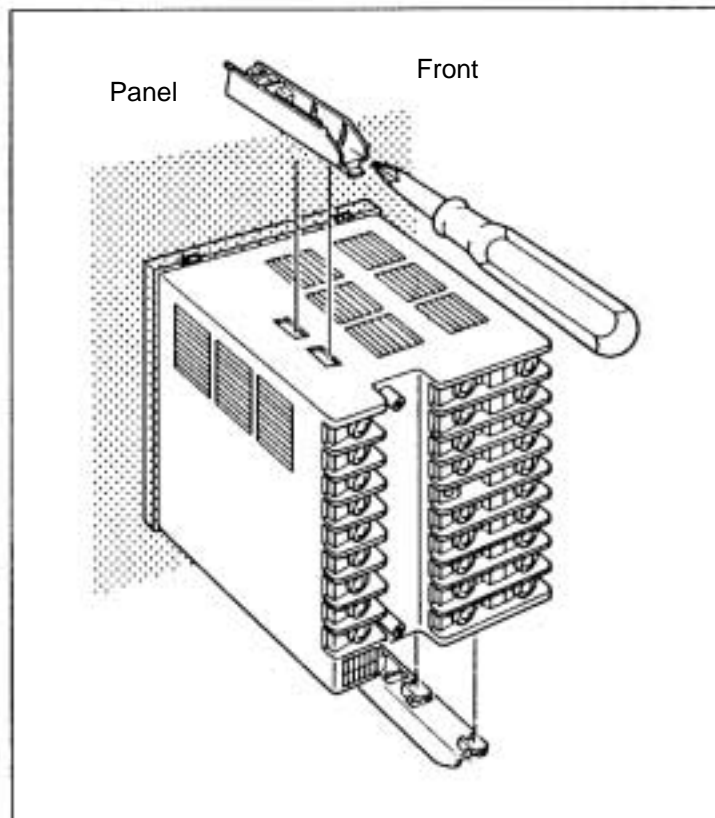

Mounting method (SDC21)

## 2-6 External Dimensions of Current Transformer

This current transformer is used to detect a heater breakage in a model provided with a heater breakage alarm function at option. The current transformer is available by request.

**CT (5.8 mm dia.) — QN206A**

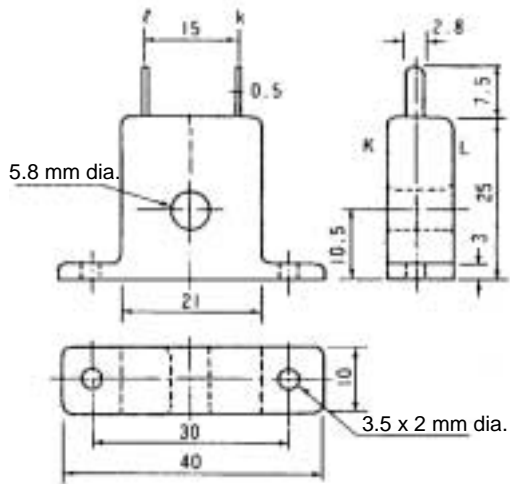



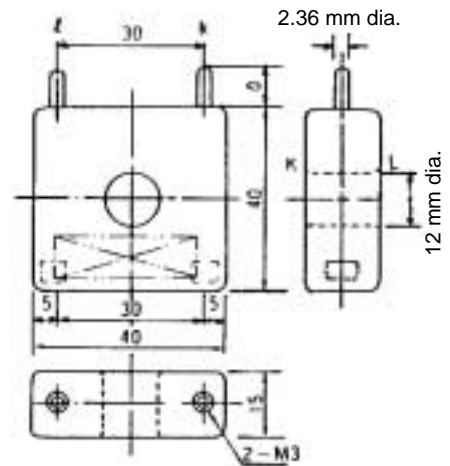

**CT (12 mm dia.) — QN212A**



# Chapter 3 WIRING

---

- A switch in the main supply is required near the equipment.
- In case of AC power supply models, main power supply wiring requires a (T) 0.5 A, 250 V fuse(s). (IEC127)
- The following table shows the meaning of the symbols in the terminal wiring label on the instrument top.

Symbol	Description
	Alternating current
	Direct current
	Earth (ground) terminal
	Caution, risk of electric shock
	Caution

## 3-1 Cables

Connect thermocouple wires to the terminals in case of a thermocouple input. When a thermocouple is connected to terminals, or wiring is extended, connect the wires via a shielded compensating lead wire.

- For input/output other than thermocouples, use a shielded polyethylene insulated vinyl shielded cable for instrumentation use conforming to JCS-364 or equivalent (generally called twisted shielded cable for instrumentation use).
- A shielded multiconductor microphone cord (MVVS) may be used, if electromagnetic induction noise are comparatively low.

### Reference Recommended twisted shielded cables

Fujikura Cable Co.	2 conductors	IPEV-S-0.9 mm <sup>2</sup> x 1P
	3 conductors	ITEV-S-0.9 mm <sup>2</sup> x 1P
Hitachi Cable Co.	2 conductors	KPEV-S-0.9 mm <sup>2</sup> x 1P
	3 conductors	KTEV-S-0.9 mm <sup>2</sup> x 1P

## 3-2 Terminal Connections

Use a crimped style solderless terminal compatible with M3.5 screw.

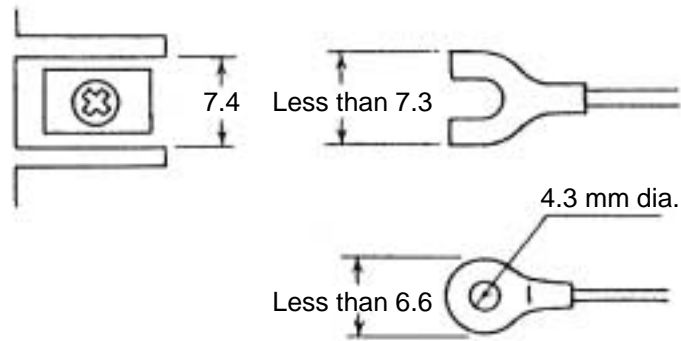

### CAUTION

- Be sure to use round crimped style solderless terminals to prevent disconnection from terminals, if the instrument is mounted at place subject to noticeable vibrations or impacts.
- Be careful not to allow any crimp style solderless terminals to touch adjacent terminals.

### 3-3 Terminal Arrangement

Terminal Arrangement (rear view)

SDC20 (48 x 96)

1	10
2	11
3	12
4	13
5	14
6	15
7	16
8	17
9	18
	19

SDC21 (96 x 96)

1		20	10
2		21	11
3		22	12
4		23	13
5		24	14
6		25	15
7		26	16
8		27	17
9		28	18
		29	19

### 3-4 Power Supply Connections

- Obtain the power source of SDC20/21 AC power supply models from a single-phase instrumentation power source not subject excess noise.
- Obtain the power source of SDC20/21 24V dc power supply models from a 24V dc  $\pm 10\%$  power source.
- If the power source generates noise, add an insulation transformer, and use a line filter. Line filter Yamatake Corporation Model No. 81446364-001

#### [AC Power supply models]

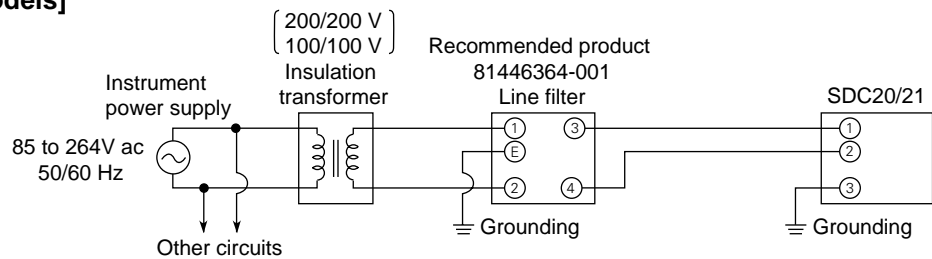

#### [24V dc Power supply models]

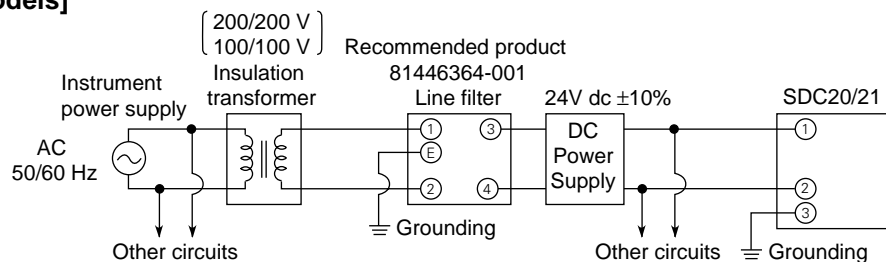

#### Reducing electrical noise

Be careful not bundle the primary and secondary coils of the power cable together. Do not put them into the same conduit or duct after introducing noise-reduction measures.

### 3-5 Grounding

Connect the instrument by one-point grounding to GND terminals (terminal ③ and ④). Do not perform any jumping wiring. Mounting a grounding terminal strip separately, and connect shielded cables, etc. to the ground, if grounding work is difficult.

Grounding type:	Lower than 100 $\Omega$
Grounding conductor:	Annealed copper wire more than 2 mm <sup>2</sup> (AWG14)
Grounding conductor length:	Max. 20 m

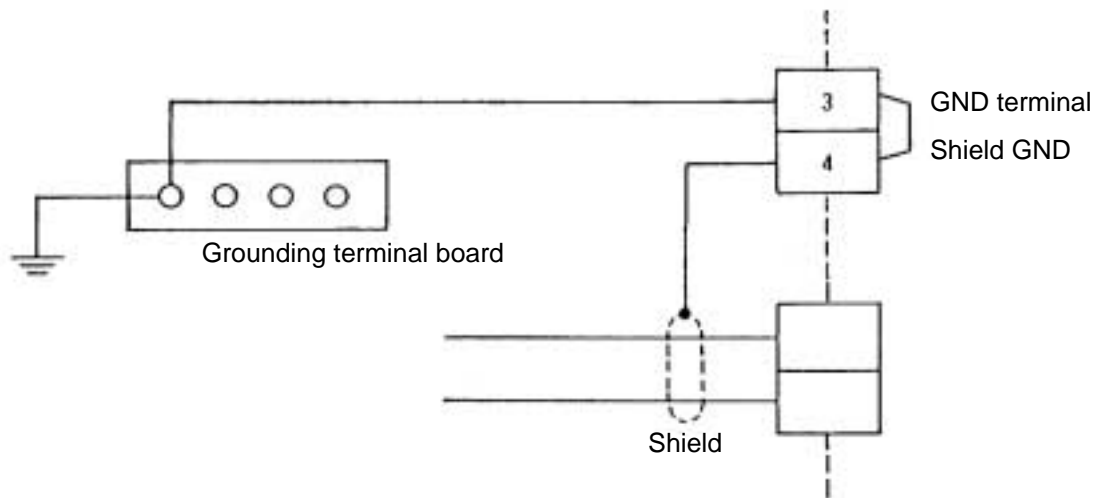

### 3-6 Input Connection

Connect the thermocouple input, resistance thermometer input, voltage input, and current input as shown below.

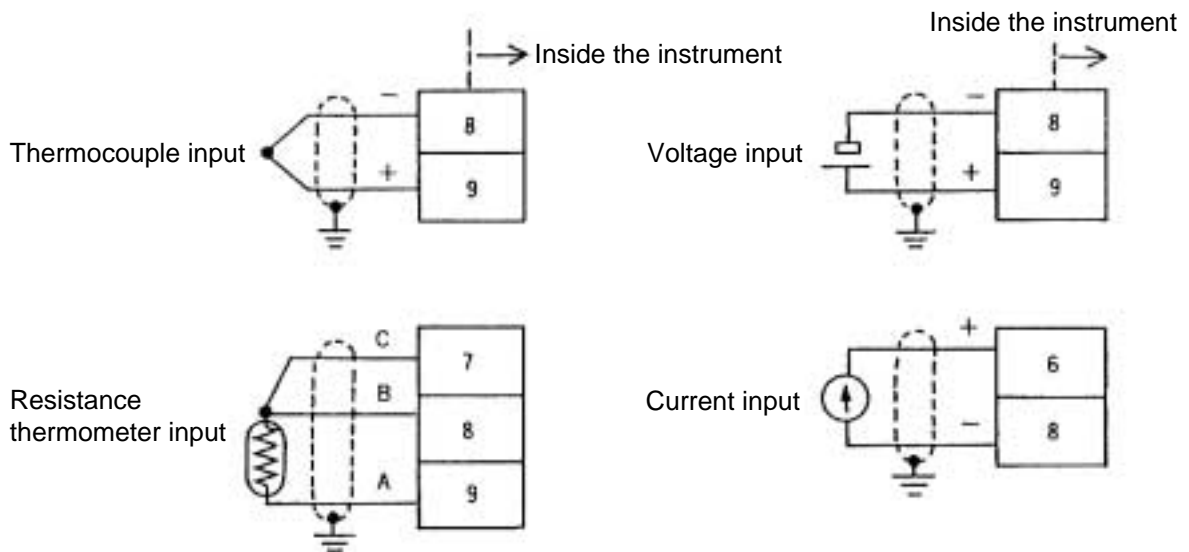

#### **CAUTION**

Be careful not to apply any voltage to current input terminals (6,8), otherwise the instrument may malfunction.

### 3-7 Output Connection

- Connect the relay output (0D), voltage output (6D), and current output (5G) as shown below.

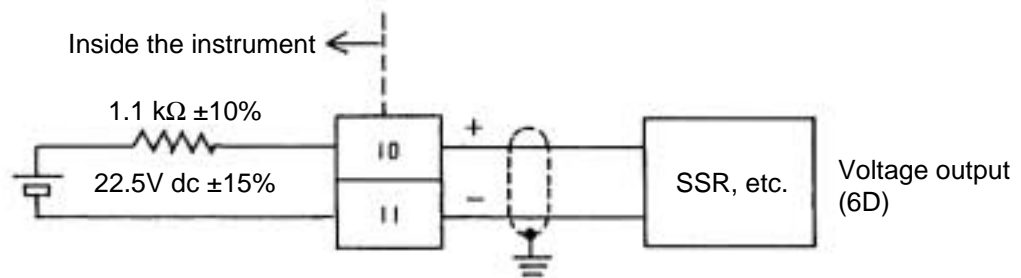
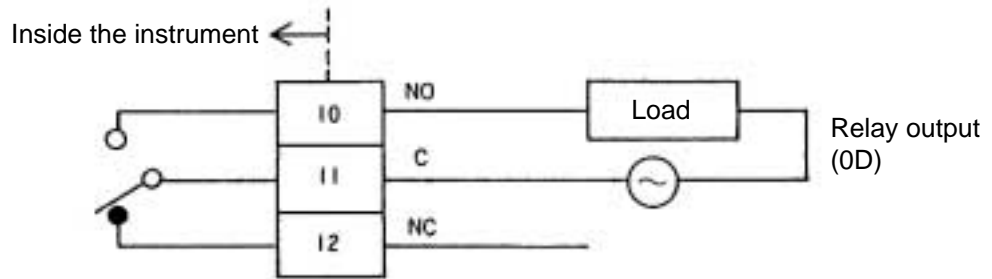

Note: The voltage output is 22.5V dc ±15%, and the internal resistance is 1.1 kΩ ±10%. If an SSR is connected as a load, examine the number of connectable SSR units according to the SSR specifications.

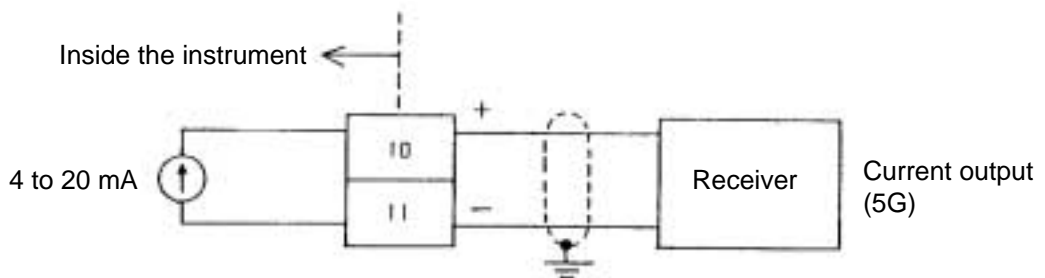

- An event output (option) is sent as follows.

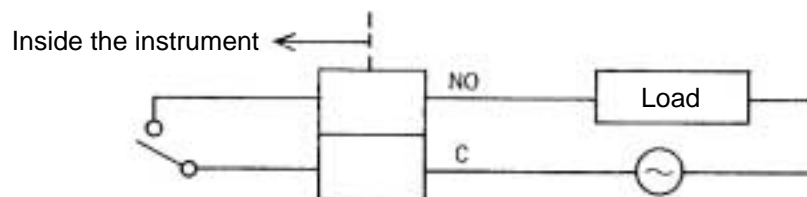

Note: Terminal numbers of the event output (optional) differ by model. Check the label mounted on the side panel of this instrument to determine the numbers.

- An auxiliary output (option) is sent as follows.

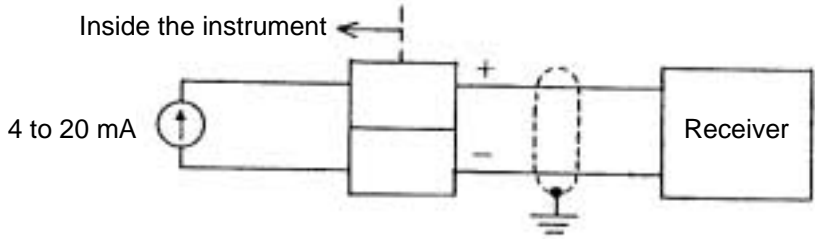

- Note 1: Terminal numbers of the auxiliary output (option) differ by model. Check the label mounted on the side panel of the instrument, to determine the numbers.
- Note 2: Isolation is not executed between the auxiliary output (5G) and others, and between the auxiliary output and voltage output (6D). Use an isolator as required. Refer to 8-2, "Specification input-output isolation", on page 8-6.

### 3-8 Connection of Remote Switch(option)

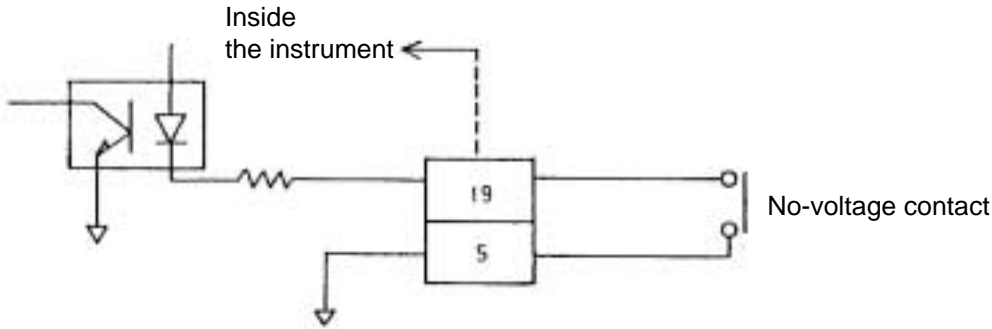

- Note: Use a non-voltage remote switch input and a micro current contact (contact type).

### 3-9 Connection of Current Transformer (CT, option)

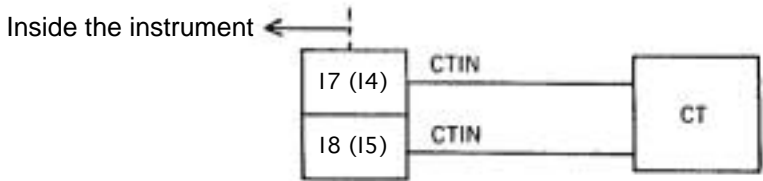

- Note: Connect a heater current conductor through the current transformer (once only).

### 3-10 Communication Connection

- The RS-232C is connected as follows.



Note: Terminal numbers of SD and RD differ by model. Refer to the label mounted on the side panel of this instrument for SD and RD number verification.

- With RS-485

### RS-485 mutual connection diagram

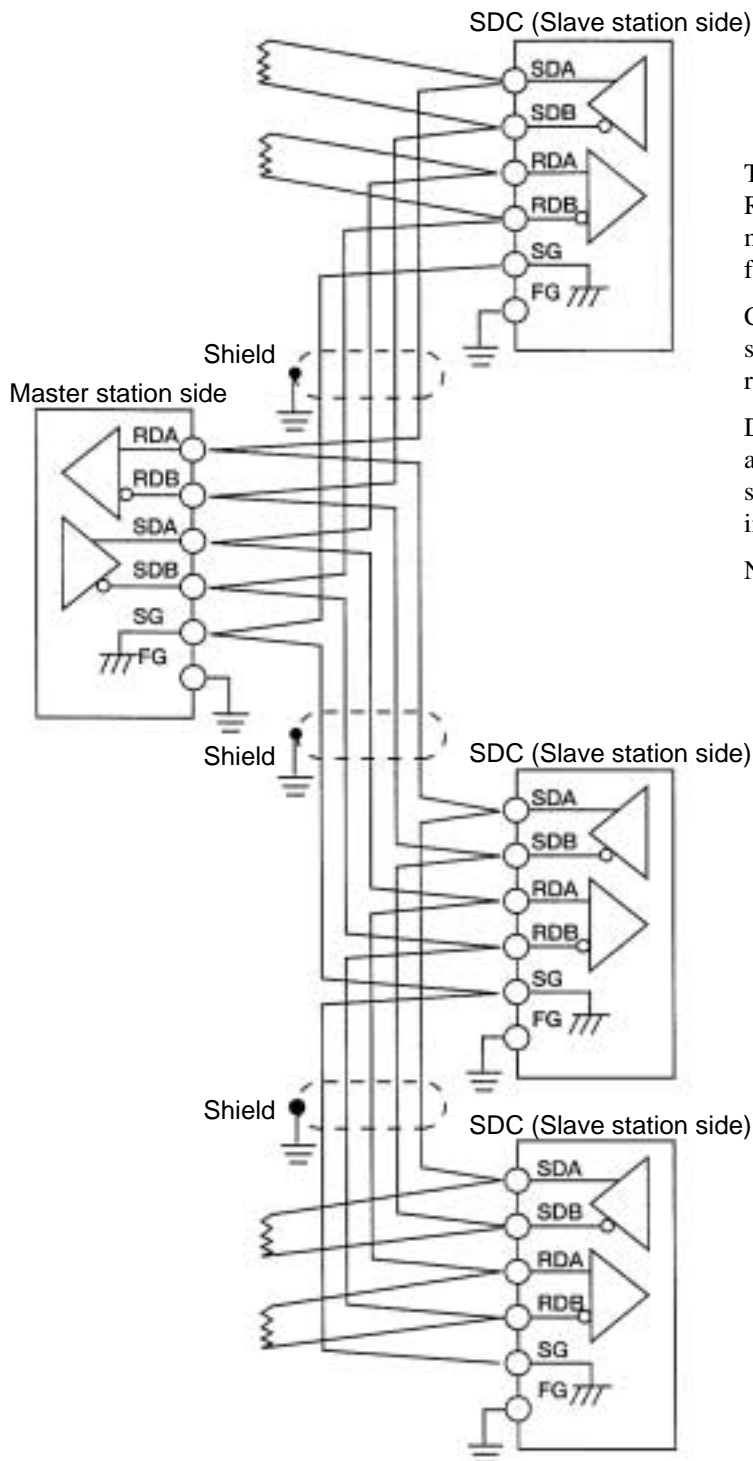

Terminal numbers of SDA, SDB, RDA, and RDB differ by model. Refer to the label mounted on the side panel of this instrument for verification.

Connect a terminating resistor in the master station and the farthest slave station. Use a resistor of 150  $\Omega$ , 1/2W or over.

Do not assign the SDC20/SDC21 to the same address as other instruments connected to the same RS-485 communication line (excluding address 0).

Note: Be sure to connect SG terminals each other. Failure to do so might cause unstable communications.

## ! CAUTION

Be careful not to short terminals across SDA and SDB or across RDA and RDB, otherwise this instrument may malfunction.

## 3-11 Wiring Precautions

- Connect cables according to the instrument model number and terminal numbers on the label mounted on the side panel of this instrument. After wiring, make sure the wiring connections are correct.
- Separate input/output signal cables and communication cables more than 50 cm from a drive power cable or a power cable higher than 100 V. Do not pass these cables together through the same conduit or duct.
- Be careful not to allow crimped style solderless terminals to touch any adjacent terminals.

## 3-12 Countermeasures Against Noise

The following noise generation sources are the most common.

- ① Relay and contacts
- ② Solenoid coils and solenoid valves
- ③ Power line (higher than 100V ac, in particular)
- ④ Inductive load
- ⑤ Motor commutator
- ⑥ Phase angle control SCR
- ⑦ Radio communication equipment
- ⑧ Welding machine
- ⑨ High-voltage ignition devices

The following methods are effective as countermeasures against noise.

- ① A CR filter is effective for quick-rising noises such as impulse noise.

Recommended CR filter

Yamatake Corporation      Model No. 81446365-001

- ② A variator is effective for noises with high crest values.

Be careful since the variator is shorted if it malfunctions.

Recommended variator

Yamatake Corporation      Model No. 81446366-001 (for 100 V)

81446367-001 (for 200 V)

# Chapter 4 **SETTING THE SETUP ITEMS**

---

This chapter provides descriptions on the setup items required for the instrument built in an equipment for the first time to be put in operating states.

It is necessary to set the operating conditions such as the input range and control action according to how to use the equipment, before operating the instrument. This is called a setup.

If the instrument has already been built in and its setup has been completed, this chapter may be skipped.

## **4-1 Setup Operation**

Before starting the setup, check the items and set values, which meet the equipment to be used, in accordance with the setup items table. Determine the setup values in advance, using the "Setting Work Sheets" attached at the end of this manual as an appendix.

To execute the setup, place this instrument in the basic indication states.

The basic indication states means such that the No.1 indicator shows a PV, and No.2 indicator shows an SR, OUT or a heater current value.

If the instrument is not in the basic indication states, press the DISP key.

There are 29 setup items from C01 to C39 (including missing numbers).

Among these items, set the necessary items only.

Some items may use the initial values as they are.

If there is no relevant item due to a special model, this Item No. is not indicated, but skipped. Setup item C40 is used for factory adjustment.

After C40, C01 follows.

## 4-2 Setup Table

Setup item	Indication	Action	Reference page
Key lock	$\overline{C} 0 1$	Sets whether or not key operation is enabled.	4-5
Temperature unit	$\overline{C} 0 2$	Selects °C or °F.	4-5
Control action	$\overline{C} 0 3$	Determines the direction of control action.	4-5
Type of PV input range	$\overline{C} 0 4$	Determines the type and range of a PV input.	4-6
Decimal point position	$\overline{C} 0 5$	Determines the decimal point position in PV, SP indication.	4-8
PV range low-limit	$\overline{C} 0 6$	Determines the PV input range.	4-8
PV range high-limit	$\overline{C} 0 7$	Determines the PV input range.	4-8
SP setting system	$\overline{C} 0 8$	Sets either single SP or multi SP.	4-8
Lower-limit of SP	$\overline{C} 0 9$	Determines an SP setting range.	4-9
Upper-limit or SP	$\overline{C} 1 0$	Determines an SP setting range.	4-9
Selection of output in case of PV abnormal	$\overline{C} 1 1$	Selects the type of output when a PV input is abnormal.	4-9
Setting of output in case of PV abnormal and when READY mode	$\overline{C} 1 2$	Determines the value of output when a PV input is abnormal and when READY mode.	4-9
Time proportional cycle	$\overline{C} 1 3$	Determines the cycle in units of second (in model 0D, 6D).	4-9
Initial manipulated variable in PID operation	$\overline{C} 1 5$	Determines the PID control output values when the power supply is turned on or AT is finished.	4-9
PID operation initialize	$\overline{C} 1 6$	Initializes the PID operation so that the output may not change suddenly when an SP value is changed.	4-10
Control system selection	$\overline{C} 1 8$	Selects the overshoot suppression function during control action.	4-10
Type of auxiliary output	$\overline{C} 2 1$	Type of auxiliary output	4-12
Green belt	$\overline{C} 2 3$	Determines the absolute value of PV-SP. The green belt lights when this value is lower than a specified value.	4-12
Event 1 type	$\overline{C} 2 4$	Determines the type of Event 1.	4-13
Event 2 type	$\overline{C} 2 5$	Determines the type of Event 2.	4-13
Event 3 type	$\overline{C} 2 6$	Determines the type of Event 3.	4-13
Remote switch function	$\overline{C} 2 7$	Determines the function of the remote switch.	4-16
Communication address	$\overline{C} 3 1$	Determines the communication address.	4-17
Transmission speed	$\overline{C} 3 2$	Determines the communication speed.	4-17
Communication code	$\overline{C} 3 3$	Determines the type of communication code.	4-17
SP ramp up gradient	$\overline{C} 3 5$	Makes variation per unit time constant when an SP value is changed.	4-17
SP ramp down gradient	$\overline{C} 3 6$	Makes variation per unit time constant when an SP value is changed.	4-17
Zener barrier adjustment	$\overline{C} 3 9$	Corrects dispersion in Zener barrier resistance value.	4-18

### 4-3 Basic Operation for Setup

In this instruction manual, the purpose of operation and the operation procedure are given on the left side of page, and the result of operation and the states indicated on the instrument are given on the right side.

The basic operation for set up is as follows;

#### Operation Procedure

- ① To set to basic indication status



Press the  key.

← A PV set value at that time is indicated.

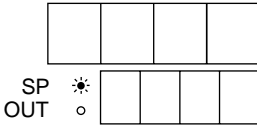
← The set value of that item is indicated.





Note) This procedure is not required when the basic indication is already given.
- ② To indicate the setup item seconds.

Continuously, press the  key and  keys together for 3 seconds.

← C01 is indicated.

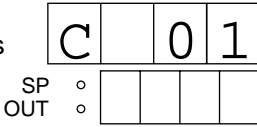

← The set value of that item is indicated.

- ③ To change the set value

(Jump to step 6 in otherwise case), press the  key.

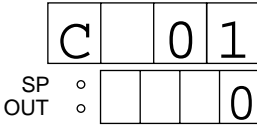
← The numeric flashes.

- ④ To change the set value

Change the numeric, using the  key or  key.

← Keeps flashing.

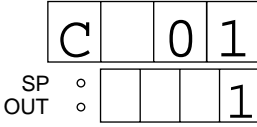
- ⑤ To define the changed numeric

Press the  key.  
→ Flashing stops and the set value is defined.

← Does not flash.

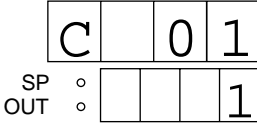

- ⑥ To transfer to the next setup item

After making sure that the numeric does not flash, press the  key.

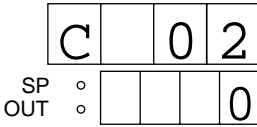
← C02 is indicated in this case.





Note) To reset to the preceding setup item, press the  key.
- ⑦ To change the numeric  
→ Repeat steps ③→④→⑤→⑥

Not to change the numeric  
→ Press the  key to transfer to the next setup.

← A PV numeric is indicated.

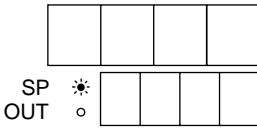

← An SP numeric is indicated.

- ⑧ To reset to basic indication status.

Press the  key.



### One Point Memo

This is a convenient function to be memorized.

How to use the up  key or down  key.

To change the set values of the indicator, use these key.

When the  key is pressed once, the numeric is incremented by one. When the down key is pressed once, the numeric is decremented by one.

When the up  key or down  key is pressed continuously, the numeric in the indicator is continuously incremented or decremented, and more over the changing speed is accelerated gradually.

When this function is used effectively, the set value can be changed greatly and conveniently.

An example is given below.

(Example) To change the numeric from 500 to 1000.

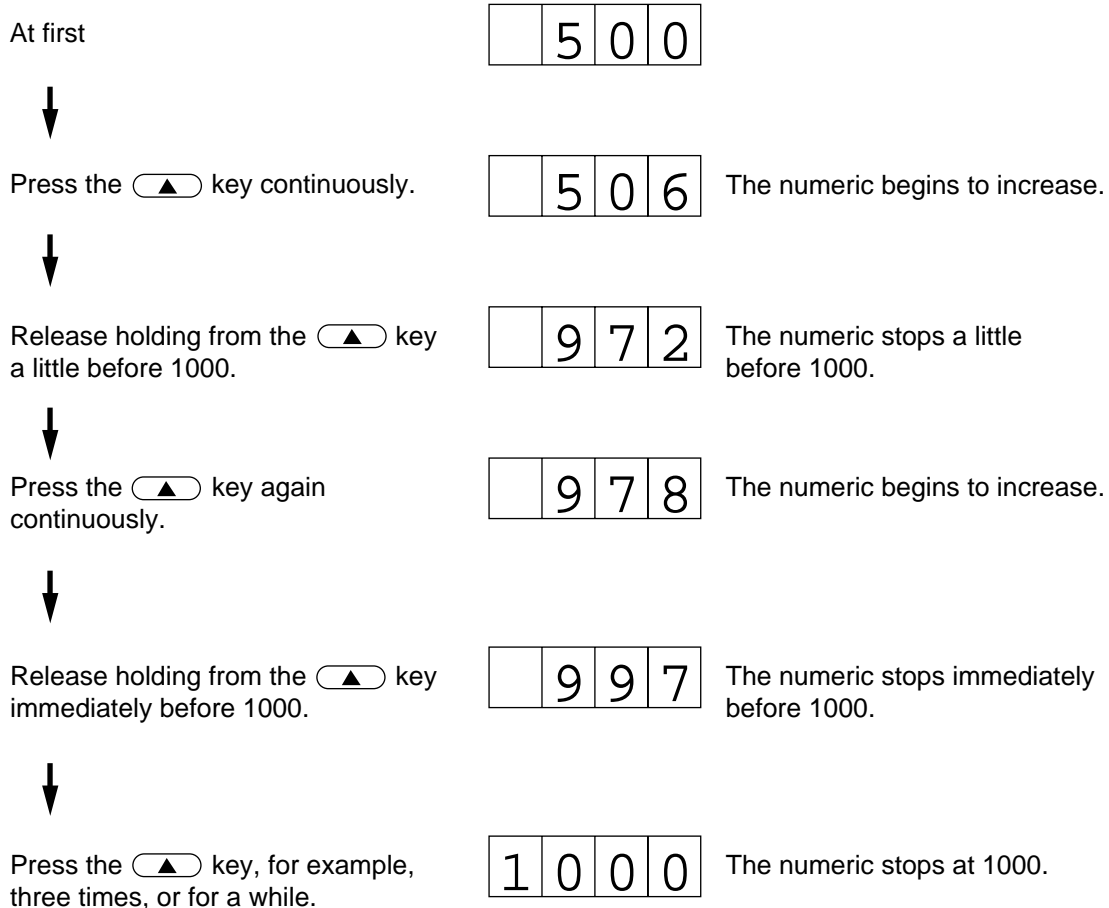

## 4-4 Description on the Setup Items

### Setup of C01 (key lock)

This setup prevents a set numeric from being changed, although it can be indicated.

The control action is prevented from being changed by an operation miss or unnecessary key operation.

0: No key lock

1: Key lock

#### *Check item*

When C01 is set to 1, any key input operation is inhibited, and the set values of all setup items and parameter items cannot be changed.

### Setup of C02 (temperature unit)

This setup selects °C or °F as temperature unit.

0: °C

1: °F

## CAUTION

- After changing the temperature unit, check if C06, C07 (upper and lower limits of PV input range), C05 (decimal point position), C09, C10 (upper and lower limits of SP limit) and event set values are correct.
- When selection is done, the upper and lower limits of a PV input range, and the upper and lower limits of an SP range are changed into the full spans.

### Setup of C03 (control action)

This setup determines the directions of control action. When the output increases as a PV increases, the control action is called a direct action, and the otherwise control action is called a reverse action.

0: Reverse action

1: Direct action

## CAUTION

Be careful about the relation to the controlled system.

Generally, select the reverse action for heating control, and the direct action for cooling control.

### **Setup of C04 (type of PV input range)**

This setup determines the type of a PV input and the reference temperature range.

Set a desired number in accordance with the input ranges table.



## **CAUTION**

After changing the input range, check if the upper and lower limits of a PV input range, decimal point position, the upper and lower limits of an SP limit, and event set values are correct.

Input Ranges Table

No.	Type	°C range	°F range
01	K	0 to 1200	0 to 2200
02		0.0 to 800.0	0 to 1400
03		-200.0 to +400.0*	-300 to +700
04	J	0 to 1200	0 to 2000
05		0.0 to 800.0	0 to 1400
06		-200.0 to +400.0*	-300 to +700
07	E	0.0 to 800.0	0 to 1400
08	T	-200.0 to +400.0*	-300 to +700
09	R	0 to 1600	0 to 3000
10	S	0 to 1600	0 to 3000
11	B	0 to 1800	0 to 3200
12	N	0 to 1300	32 to 2372
13	PLII	0 to 1300	32 to 2372
14	Wre5-26	0 to 2300	0 to 4000
16	Ni-Mo	0 to 1300	32 to 2372
17	DIN U	-200.0 to +400.0*	-300 to +700
18	DIN L	0.0 to 800.0	0 to 1400
20	JIS	-200.0 to +500.0*	-300 to +900
21	Pt 100	-100.0 to +200.0	-150.0 to +400.0
30	JIS	-200.0 to +500.0*	-300 to +900
31	Jpt 100	-100.0 to +200.0	-150.0 to +400.0
40	4 to 20 mA		Scaling and decimal point position are variable within a range of -1999 to +9999.
41	0 to 20 mA		
45	1 to 5 V		
46	0 to 5 V		
50	0 to 10 mV		
51	0 to 100 mV		
52	-10 to +10 mV		

Note: Although -200.0 cannot be indicated, the action is normal.

In the ranges with decimal point indication, indication can be performed to one decimal point.

### Setup of C05 (decimal point position)

This setup determines whether a decimal point is added to the PV indication and SP indication. With the temperature input, the range shown with a decimal point in the input ranges table can be set to one decimal digit.

A decimal point can be added to any position with a linear input.

- 0: With no decimal point
- 1: One decimal digit is indicated.
- 2: Two decimal digits are indicated.
- 3: Three decimal digits are indicated.

#### *Check items*

- This setup is disabled, depending upon the contents of setup of C04.
- When changing the decimal point position, check if the upper and lower limits of the input range, the SP set value, the upper and lower limits of the SP limit, event set values, event hysteresis, and SP ramp are correct.

### Setup of C06 (lower limit of PV input range)

### Setup of C07 (upper limit of PV input range)

With the temperature input, the PV input range can be narrowed.

For example, the reference temperature range of 0.0 to 800.0°C can be narrowed to 0.5 to 500.0°C in No.02 (input type K) of the input ranges table. In such a case, set the lower limit to 0°C, and the upper limit to 500°C.

With the linear input, desired numerics can be assigned to 0% and 100%.

For example, 4 mA can be assigned to 0 and 20 mA to 1000 in case of 4 to 20 mA input. In this case set the lower limit to 0 and the upper limit to 1000.

#### *Check items*

- With the temperature input, the input range can be setup to:  
"Upper limit value — Lower limit value  $\geq$  Reference temperature range/4 "
- When changing the upper and lower limits of the PV input range, check if the upper and lower limits of the SP limit, and event set values are correct.
- When the upper and lower limits of the PV input range have been changed, the PID constants are determined, depending upon the range changed.
- After the upper and lower limits of the SP limit are set earlier via C09 and C10, the upper and lower limits of range can be set to a narrower range, but SP is determined, depending upon the value determined as the SP limit. In such a case, set the SP limit again.

### Setup of C08 (SP setting system)

This setup selects either single SP or multi SP.

- 0: Single SP
- 1: Multi SP

**Setup of C09 (lower limit of SP limit)****Setup of C10 (upper limit of SP limit)**

This setup restricts the setup and indication of SP.

 **CAUTION**

- Set C06 and C07 after setting C09 and C10.
- This setup cannot be done out of the range of C06 and C07. However, when C09 and C10 are set earlier, C06 and C07 may be set to values smaller than the limit values.

**Setup of C11 (selection of output in case of PV over-range)**

This setup is provided to set an output when a PV input has become abnormal.

0: Normal PID operation values are output in over-range.

1: Values set via C12 in output in over-range.

**Setup of C12 (output in case of PV over-range)**

This setup is provided to set an output value when a PV input has become abnormal and when READY mode.

The unit is %. Set an output value to the safety side of equipment, for example, in the non-heating direction with a heater.

 **CAUTION**

The abnormal PV input means an output of alarm AL01, AL02, AL03 or AL70.

**Setup of C13 (time proportional cycle)**

This setup determines the output cycle in the time proportional control in model 0D, 6D.  
The unit is second.

 **CAUTION**

The item is skipped in model 5G.

**Setup of C15 (initial manipulated variable in PID operations)**

This setup determines the PID control output values (manipulated variables)

when the power supply is turned on or the auto tuning is finished. There initial values can be used as MV values.

### Setup of C16 (PID operation initialize)

This setup initializes the PID operations to prevent abrupt changes of outputs when an SP value has been changed.

- 0: initializes automatically by the decision of this instrument itself (AUT).
- 1: Initializes each time an SP value changes (initializes at time of SP change).
- 2: Not initialized (continues PID).

### Setup of C18 (control system selection)

This setup selects the function of suppressing overshoot during control action.

- 0: Normal PID.
- 1: Overshoot relaxation:           A certain overshoot suppression effect is obtainable.  
  However, the suppression strength is fixed.
- 2: Learning function condition:   Optimum suppression strength is learnt according to a control system.
- 3: Fixed learning condition:       The optimum suppression strength obtained by learning is fixed.

In the initial control action, operate the instrument with C=0, and check overshoot states.

When there is an overshoot, set C18 to 1 and check if the overshoot is of a satisfactory value during control action.

When satisfactory, this learning is terminated as it is.

If not, set C18 to 2, and execute learning by repetitive control.

Repeat the learning until the satisfactory results are obtained. When the results of learning are satisfactory, set C18 to 3, and fix the results of learning to terminate the learning.

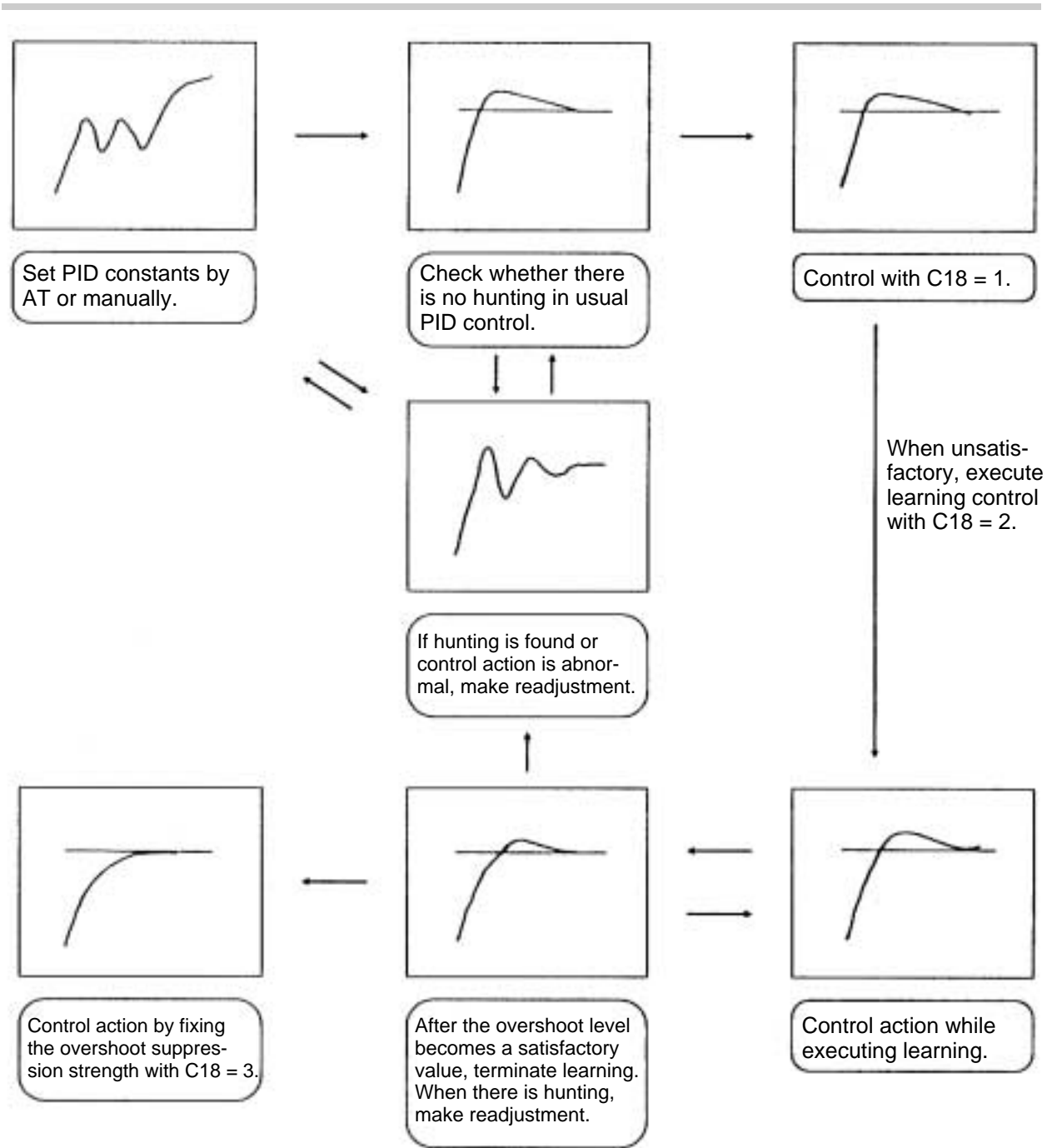

Learning Control Application Concept Diagram

 **CAUTION**

- Before selecting the overshoot suppression function, execute the auto tuning and set optimum PID constants.
- If there is hunting in the control action, the overshoot suppression function is not activated satisfactory.  
In such a case, reset the PID constant.
- When SP is changed with C18=2, the suppression strength is rewritten as soon as learning is terminated.
- If any of the following items occurs during learning, the learning is interrupted.
  - ① When SP is changed.
  - ② When auto tuning is executed.
  - ③ When the SP ramp is executed.
  - ④ When an alarm occurs.

**Setup of C21 (type of auxiliary output) (optional)**

The auxiliary output is sent as a 4 to 20 mA dc current signal.

The contents can be selected by PV, SP or MV (manipulated variable).

0: PV

1: SP

2: MV (manipulated variable)

Zero and span outputs are as specified below.

Type output	Zero (4 mA)	Span (20 mA)
SP	Lower-limit value of SP (C9)	Upper-limit value of SP (C10)
PV	Lower-limit value of PV range (C6)	Upper-limit value of PV range (C7)
Manipulated variable	0% (Fixed value)	100% (Fixed value)

A PV output value or a manipulated variable output value ranges from -10% (2.4 mA) to +110% (21.6 mA).

**Setup of C23 (green belt)**

This setup indicates that a control value is within a specified range.

The green belt lights when the absolute value of the control deviation (PV-SP) becomes lower than a specified value.

This setup is used to set a control deviation value when the green belt lights.

### Setup of C24, C25 and C26 (event types) (optional)

If the event output relay is added (optional), a maximum of 3 points can be set, depending on the model. The operating conditions can be set independently for each output.

The types and functions of events are shown below. “EV” shows an event set value, while “F” shows a hysteresis set value.

Set the event 1 in C24, the event 2 in C25, and the event 3 in C26.

For the event type setting, use the event codes shown in the following event codes table.

**Event Codes Table**

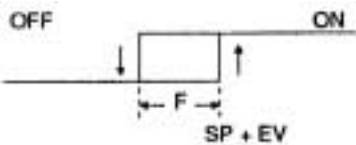
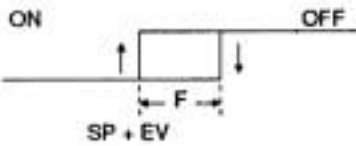
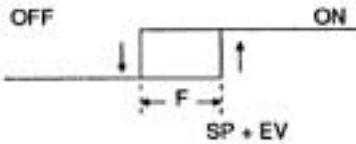
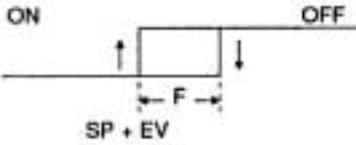
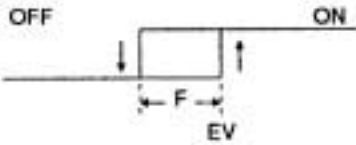
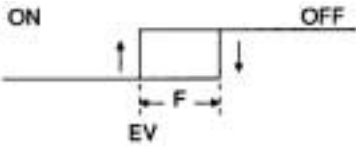
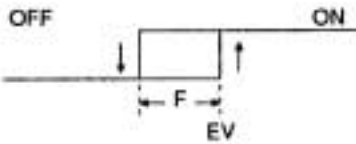
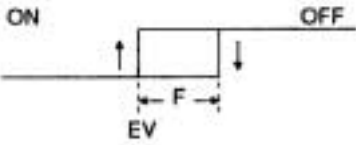
Code	Types of event	Action	Remarks
1	Deviation Direct action		
2	Deviation Reverse action		
3	Deviation Direct action with standby		Event on the condition that the event output function is turned on when the power supply is turned on, the event output function is kept off in standby status unless the condition for event output off is satisfied once.
4	Deviation Reverse action with standby		
5	PV Direct action		
6	PV Reverse action		
7	PV Direct action with standby		* Same as code 3, 4
8	PV Reverse action with standby		

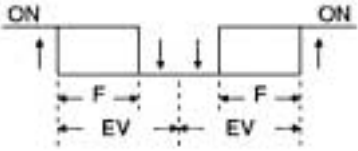
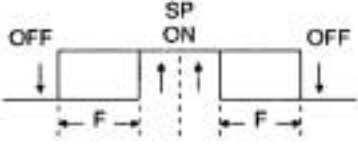
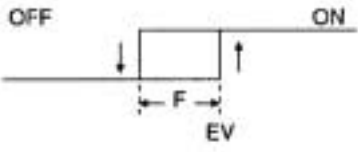
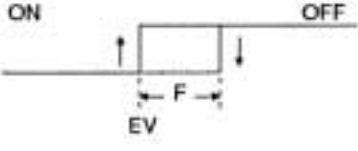
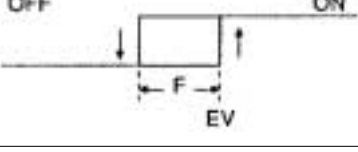
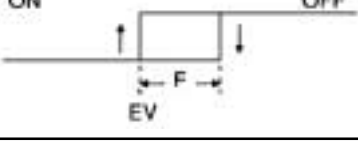
Code	Types of event	Action	Remarks
9	Absolute value deviation Direct action		
10	Reverse action		
11	Absolute value deviation Direct action with standby	Same as code 9	* Same as code 3, 4
12	Absolute value deviation Reverse action with standby	Same as code 10	
13	SP Direct action		
14	SP Reverse action		
15	SP Direct action with standby		* Same as code 3, 4
16	SP Reverse action with standby		

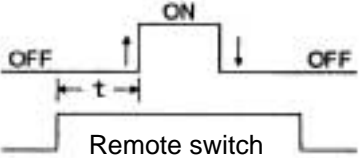
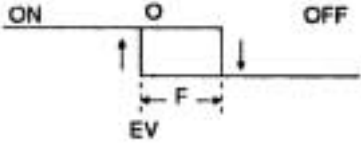
Code	Types of event	Action	Remarks
17	Alarm	ON during alarm occurrence	This is output when an alarm occurs. There are none of setting range and hysteresis.
18	Timer		There is no hysteresis. Used in combination with remote switch. Only one point of timer event can be assigned.
19	Heater breakage		
0		Event OFF	

① The event set value range by the SP/EV key is as shown below.

Event	Setting range
Deviation	$\pm$ PV range span / 2 (more than -1999 unit)
PV	Within PV range
Absolute value deviation	0 to PV range span / 2
SP	Within SP limit range
Timer	1 to 9999 sec.
Heater breakage	0.0 to 50.0 A

### CAUTION

- The initial values of C24 to C26 are 0 (event off) even in a model with the event function.

Unless the type of the event is set, Hys1 to Hys3 are not indicated even when parameters are set.

EV1 to EV3 cannot also be set by the SP/EV key.

- The heater breakage event is provided, it can be used not only as a heater breakage event but also as other events.
- The heater breakage event can be assigned to multiple events.

In this case, different set values are allowable.

(Example) E1 = 30 A, E2 = 20 A, E3 = 10 A

### Setup of C27 (remote switch function)

If the remote switch (optional) is provided, one of the following action can be selected.

0: Non operation

1: READY/RUN selection

When the remote switch is turned off, this instrument executes normal control action.

When the remote switch is turned on, the instrument is set to ready states, and the control action stops. A set value of C is then sent as a control output. The green belt flashes under ready states.

2: SP selection

With the multi SP, either SP0 or SP1 can be selected via the remote switch.

SP0 is selected when the remote switch is turned off, and SP1 is selected when it is turned on.

In this case, no SP can be selected via keying operations.

**3: Timer event drive**

The timer event is started and reset by the remote switch.

By turning on the remote switch, the timer event is started to turn on the event output after a preset time.

By turning off the remote switch, the timer is reset to turn off the event output.

**Check items**

- The remote switch must be held for 400 ms or more after it is turned on.
- The timer is reset by turning off the remote switch during timer operation. The remote switch must be kept turned on until the event is output.

**Setup of C31 (communication address)**

This setup is used when the communication function is provided as option. Set the communication address from 0 to 127.

**Setup of C32 (transmission speed)**

This setup is used when the communication function is provided at option.

- 0: 9600bps
- 1: 4800 bps
- 2: 2400 bps
- 3: 1200 bps

**Setup of C33 (communication code)**

This setup is used when the communication function is provided at option.

- 0: 8 bits, even parity, and 1 stop bit
- 1: 8 bits, even parity, and 2 stop bits

**Setup of C35 (SP ramp up gradient)****Setup of C36 (SP ramp down gradient)**

The SP ramp function makes the set point changing rate per unit time constant when changing an SP value.

It prevents the control output from changing suddenly due to a sudden change in SP.

The function also functions when the SP selection is changed in multi SP. The unit shown is in unit/min.

**Check items**

- If the gradient is set to 0, the SP ramp does not function, and the SP is set to the point just after the change.
- When the instrument power supply is turned on, the PV value is regarded as the start point of the SP ramp after about 2.5 seconds.

- When the READY condition has been changed to the RUN condition via the remote switch, the PV value at that time is regarded as the start point of the SP ramp.

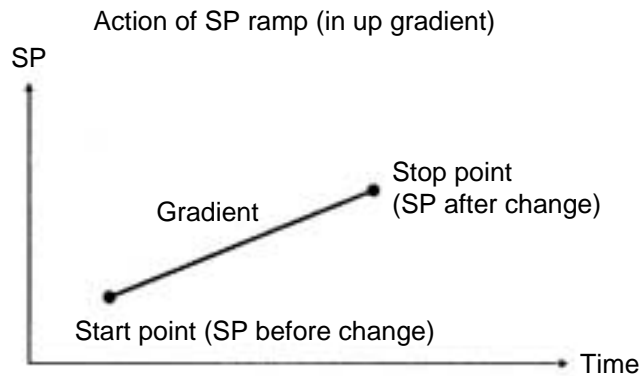

### Set up of C39 (zener barrier adjustment)

This instrument must be adjusted to correct a dispersion of the resistance value of Zener barriers with models having an additional Zener barrier processing function with a resistance thermometer bulb input.

#### Preparation

Connect a Zener barrier into A, B, C lines respectively, and short both ends of the resistance thermometer bulb.

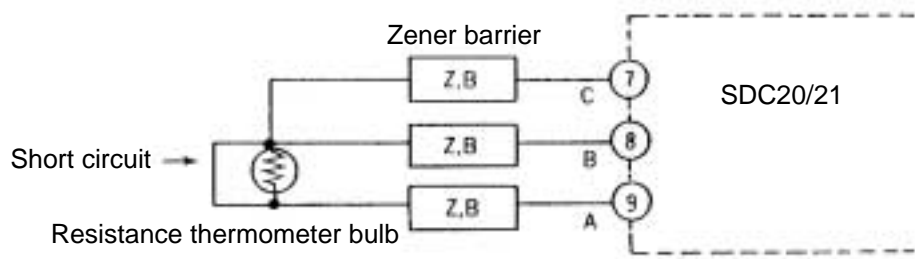

- ① Indicate C39 in No.1 indicator.

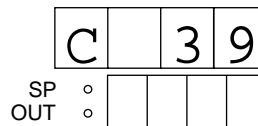

- ② Indicate the differential resistance of Zener barriers (A-B).

Press the **ENT** key.

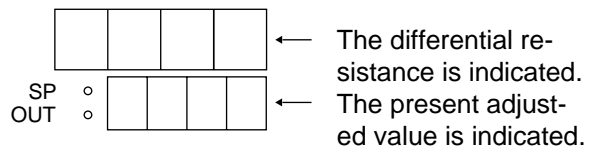

- ③ Define the adjusted value.

Press the **ENT** key again.

Note 1: Use a Zener barrier having a resistance of 70  $\Omega$  or less.

The resistance difference between the Zener diodes connected to A and B lines should be less than 20  $\Omega$ , otherwise no adjustment is possible.

Note 2: This adjustment is not necessary if the instrument is used with an input other than a resistance thermometer bulb input.

Note 3: If no Zener barrier is used, this adjustment is not necessary even if the instrument is used with resistance thermometer bulb input.



## CAUTION

When Zener barrier adjustment is performed once, the instrument cannot be used with a resistance thermometer bulb input lacking Zener barrier. In such a case, the above adjustment must be done without Zener barriers.

This page left intentionally blank

---

# Chapter 5 SETTING OF PARAMETERS

## 5-1 Parameters Table

The following parameters are provided.

Parameters Table

No.	Item	Indication	Setting condition	Initial value	Setting range	Remarks
①	Auto tuning start/stop	<i>AL</i>	—	0	0: Execution stops 1: Execution starts	
②	Proportional band	<i>P</i>	—	5.0	0.0 to 999.9%	Applied to models 0D and 6D.
					0.1 to 999.9%	Applied to model 5G.
③	Integral time	<i>I</i>	P ≠ 0	120	0 to 3600 sec.	
④	Derivative time	<i>D</i>	P ≠ 0	30	0 to 1200 sec.	
⑤	Lower-limit of manipulated variable	<i>oL</i>	P ≠ 0	0	0 to upper-limit %	
⑥	Upper-limit of manipulated variable	<i>oH</i>	P ≠ 0	100	Lower-limit to 100%	
⑦	Manual reset	<i>rE</i>	I = 0 & P ≠ 0	50	0 to 100%	
	Differential	<i>diFF</i>	P = 0	5	1 to 100 unit	
⑧	PID1	A number is added to the above number.	C8 = 1 With Multi SP	Same as specified above.	Same as specified above.	
⑨	Set point 0	<i>SP 0</i>	C8 = 1 With Multi SP	0	Depends upon SP limits (C9, C10).	
	Set point 1	<i>SP 1</i>				
⑩	EV1 hysteresis	<i>HY51</i>	Option EV1 is provided	5	0 to 100 unit	Can not be set in alarm event or timer event modes.
⑪	EV2 hysteresis	<i>HY52</i>	Option EV2 is provided			
⑫	EV3 hysteresis	<i>HY53</i>	Option EV3 is provided			
⑬	PV bias	<i>PbIA</i>	—	0	±1000 unit	

Note 1: In ⑧ PID, ② to ⑦ are repeated by adding this number.  
(P1, I1, d1.oL1, oH1, rE1/diFF1)

Note 2: After ⑬, ① follows.

Note 3: If an item is not set or it has no function, it is not indicated.

## 5-2 Basic Parameter Operation

The basic operation methods for parameters and examples of their execution are shown below.

### Operation Procedure

The procedure for setting the execution start of auto tuning is shown below.

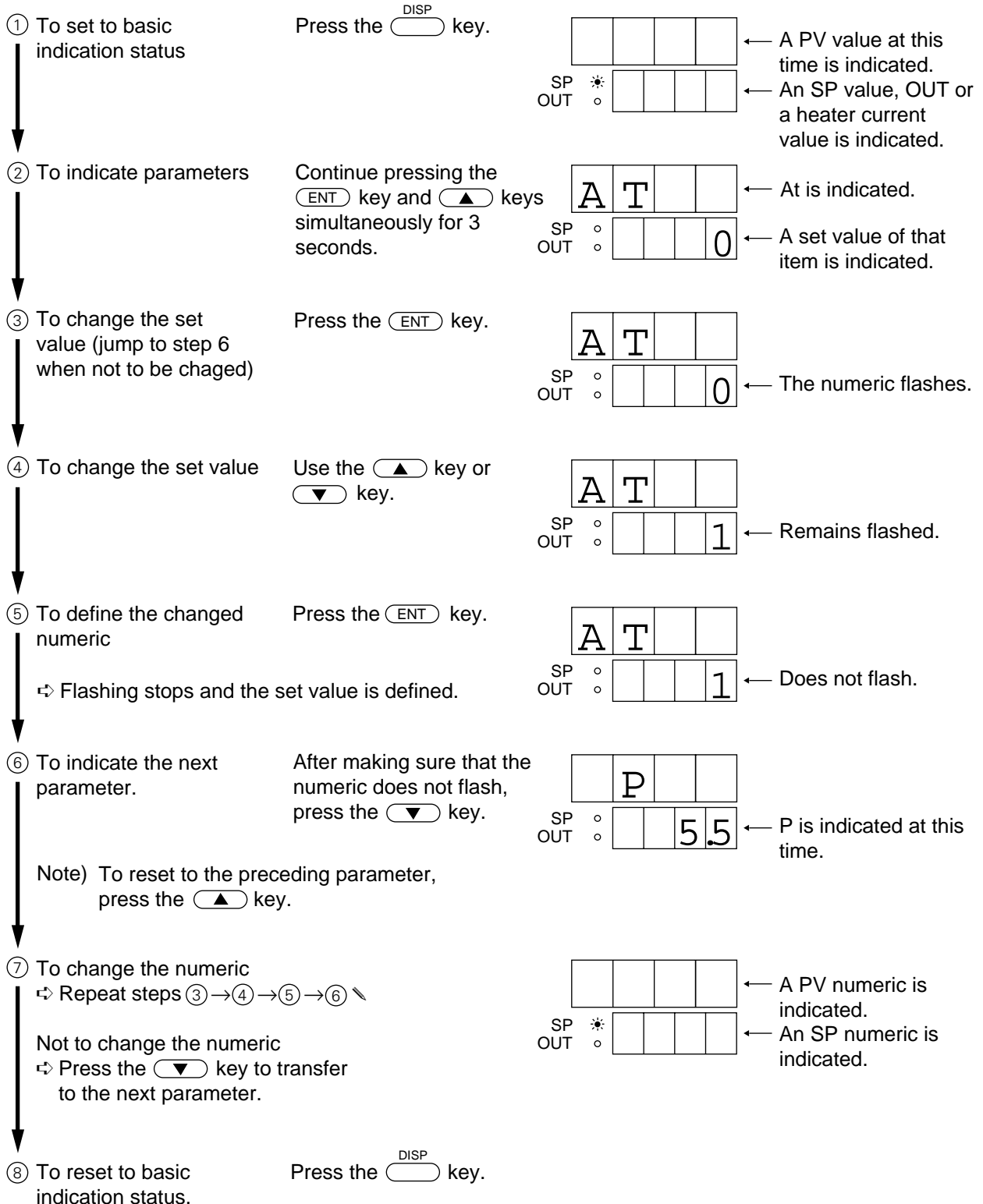

### 5-3 Assigning a Parameter to the **PARA** Key

This instrument can assign parameters, which are often used during operation, to the **PARA** key, and call them as required, using the **PARA** key only.

A maximum of eight parameters can be assign to the **PARA** key.

#### Operation Procedure

The procedure for assigning the auto tuning (At) to the **PARA** key is shown below.

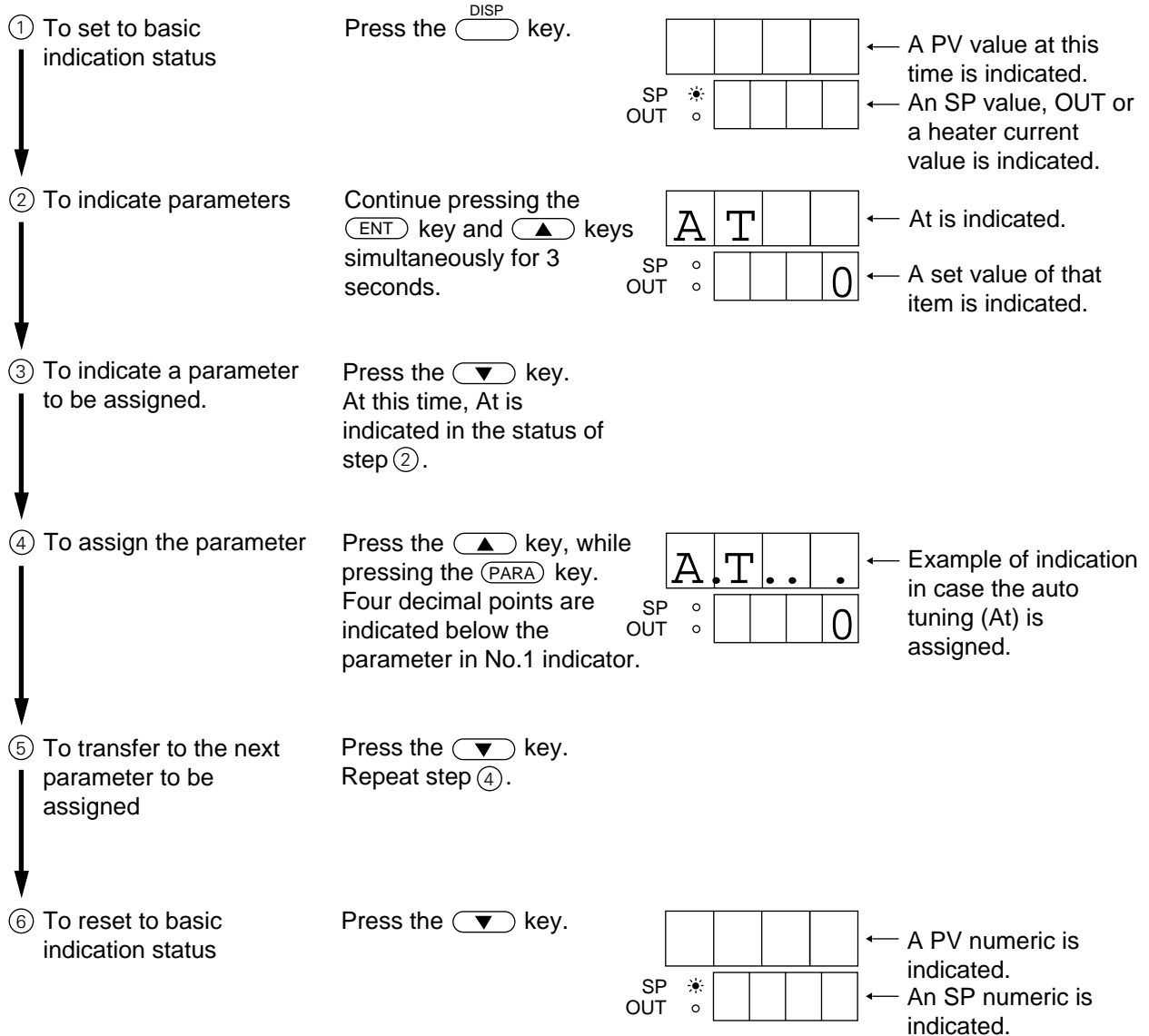

### **!** CAUTION

If 9 or more parameters are attempted to be assigned, the parameter(s) assigned at first is reset, and the new parameter(s) is assigned.

## 5-4 Resetting a Parameter Assigned to the **PARA** Key

### Operation Procedure

The procedure for resetting the auto tuning (At) assigned to the **PARA** key is shown below.

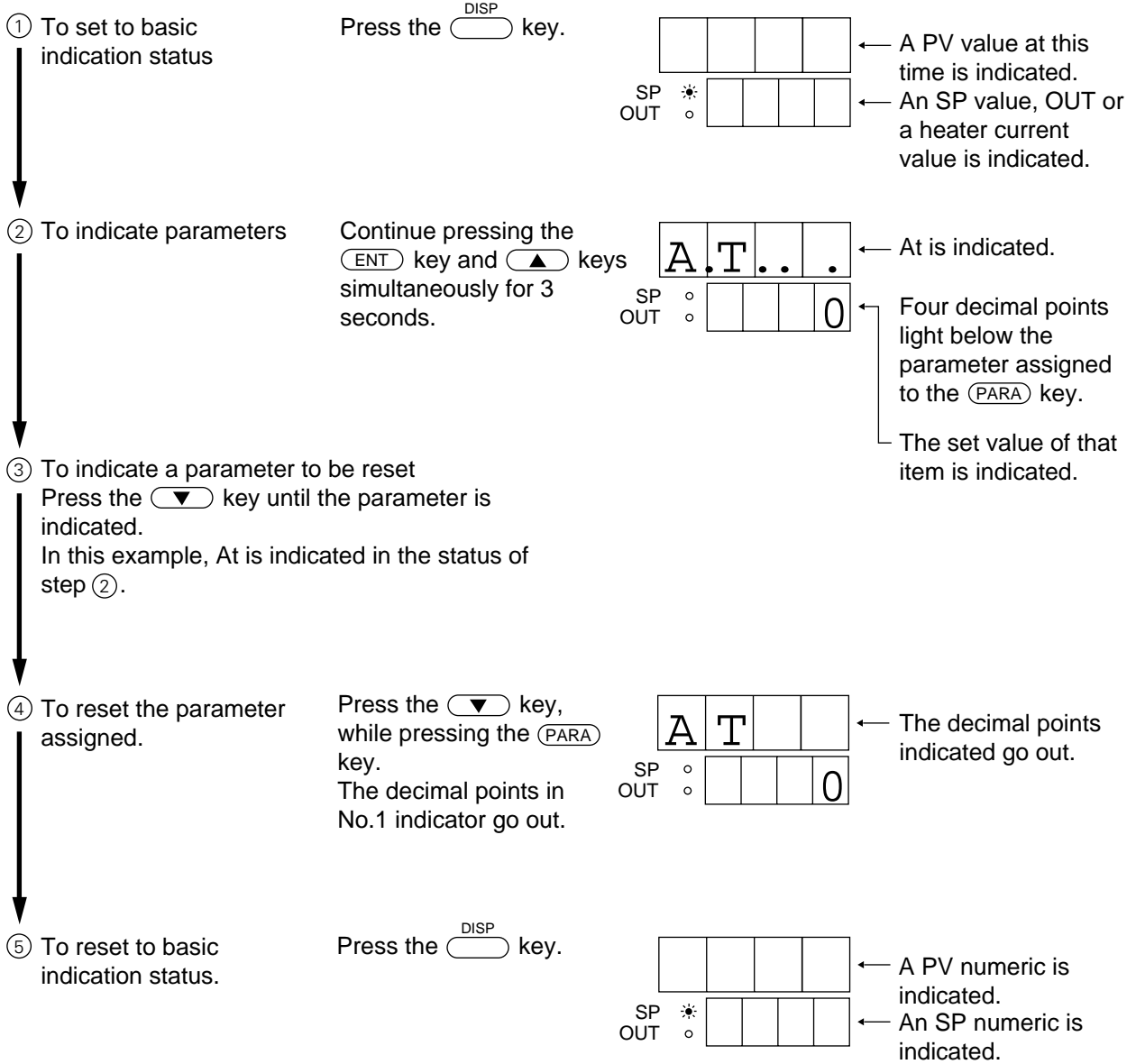

## 5-5 Operation of Parameters Assigned

The set values of parameters assigned to the (PARA) key can be checked or changed by one touch operation.

### Operation Procedure

The procedure for changing the SP1 assigned to the (PARA) key from 100°C to 200°C is shown below.

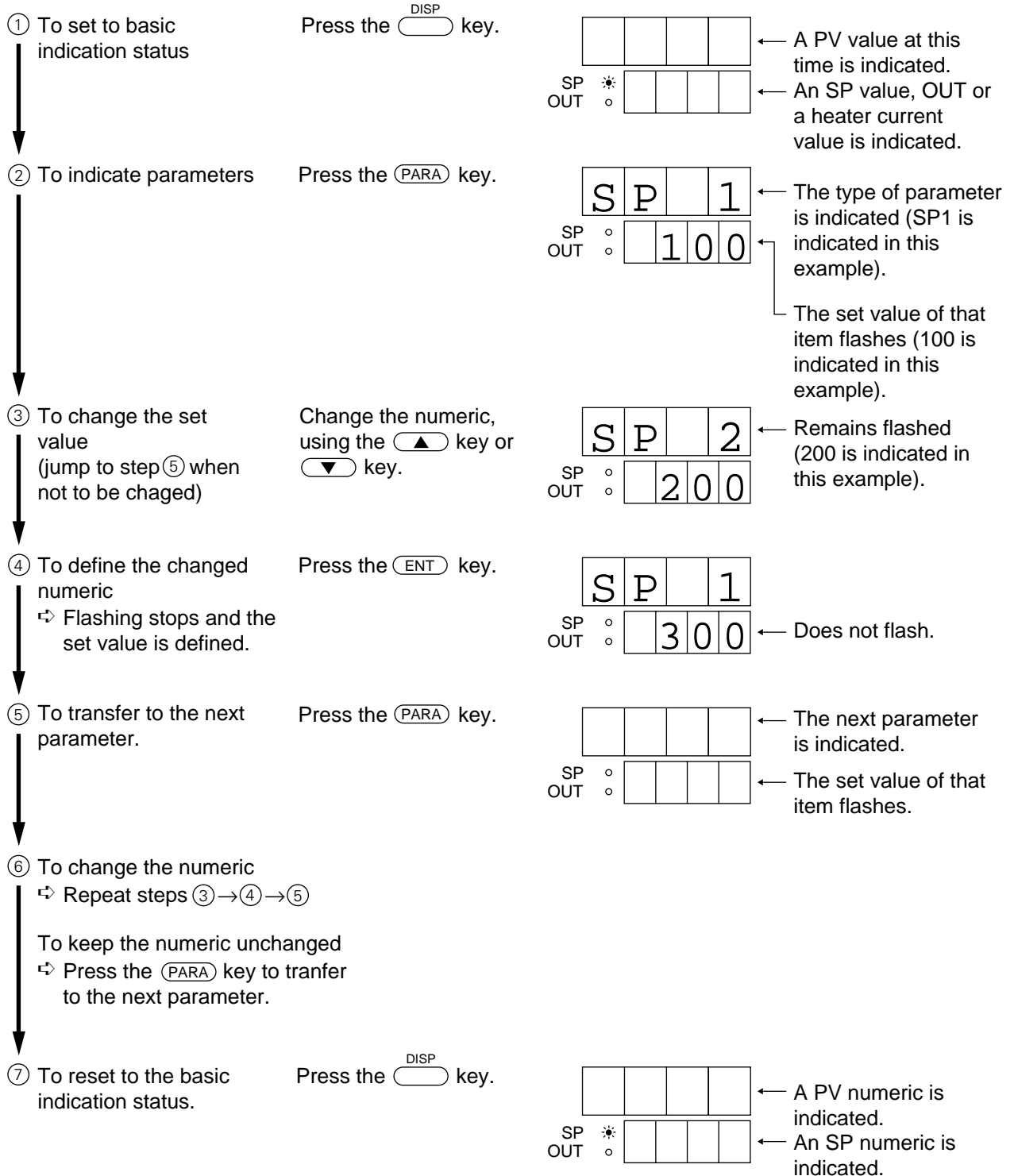

Note) The parameters are indicated in the order of assignment.

## 5-6 Description on Parameters

### PID constants

When multi SP is selected in the setup item C08 (SP setting system), two groups of PID constants are prepared.

P, I, D correspond to SP0, while P1, I1, D1 correspond to SP1.

Determine P=Proportional band, I=Integral time and D=Derivative time.

When setting I to 0, the integral action turns off so that the manual reset can be set.

When setting P to 0, the on-off action is selected, and the differential can be set.

However, P=0 cannot be set in model 5G (current output)

### Check items

- When setting P to other than 0, the differential cannot be set.
- When setting I to other than 0, the manual reset cannot be set.

### Upper and lower limits of manipulated variable (oH, oL)

These parameters oH and oL determine the upper and lower limits of the manipulated variable.

They also serve as the upper and lower limits of the integral limiter.

### Check items

The setting ranges of oL and oH are 0 to oH and oL to 100, respectively.

### Manual reset (rE)

This is used for manually obtaining a control deviation when the integral is turned off.

This can be done when I=0 and P≠0.

### Differential (dIFF)

This parameters can set a difference between the on point and the off point (differential, dead band) in on-off action.

When P=0, the on-off action is then ready to set the differential. However, P=0 cannot be set in 5G (current output).

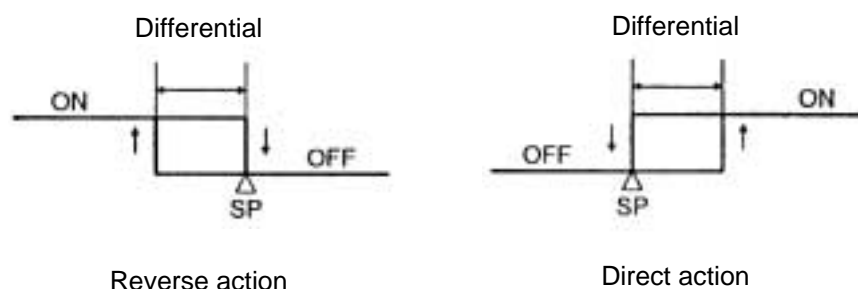

### **Set point (SP0, SP1)**

When multi SP is selected in the setup item C08 (SP setting system), two groups of SP are prepared.

### **Event hysteresis (HYS1 to HYS3)**

This parameter can set a difference between the event on and off points. (hysteresis dead band)

However, this parameter cannot be set, in principle, in alarm event and timer event.

### **PV bias (PbIA)**

The unit set to the PV bias is added to or subtracted from a PV value.

This page left intentionally blank

---

# Chapter 6 OPERATION

## Index to Work Contents

How to use this chapter:

This chapter provides descriptions on the operational procedures to be followed concerning the check or change items often required during a run. The index to the contents of these check and change works and the pages on which the relevant descriptions are given below.

Contents of Work	Reference pages	
To indicate a PV	p.6-4	6-2. Indicating a PV
To indicate an SP	p.6-4	6-3. Indicating an SP
To indicate the output value	p.6-5	6-4. Indicating the Output Value
To indicate the heater current value	p.6-6	6-5. Indicating the Heater Current Value
To change an SP (with single SP)	p.6-7	6-6. Changing an SP (with single SP)
To change an SP (with multi SP)	p.6-8	6-7. Changing an SP (with multi SP)
To select an SP (multi SP)	p.6-9	6-8. Selecting the SP of Multi SP
To change the set value of event (option)	p.6-10	6-9. Changing the Set Value of Event
To change the set value of PV bias	p.6-11	6-10. Changing the Set Value of PV Bias
To change various parameters	p.6-12	6-11. Changing Various Parameters
(1) To start the auto tuning assigned to the <b>(PARA)</b> key	p.6-12	
(2) To stop the auto tuning	p.6-15	
(3) To change PID (proportional band, integral time, derivative time) values	p.6-16	
(4) To change oL and oH (lower and upper limits of manipulated variable) value	p.6-17	
(5) To change the rE (manual reset) value	p.6-18	
(6) To change the dIFF (differential) value	p.6-19	
(7) To change the HYS (event hysteresis) value	p.6-20	
To indicate parameters as soon as possible	p.5-3	5-3. Assigning Parameters to the <b>(PARA)</b> key

## 6-1 Turning on the Power Supply

This instrument is set to operating condition by turning on the power supply.

However, the instrument must be warmed up to satisfy the specified accuracy.

The warm up period ends after one hour or more.

The No.1 indicator does not indicate any PV for 2 to 3 seconds after turning on the power supply.

During this period, the control output becomes 0%, and no event output is sent.

### **Caution in selecting READY/RUN by remote switch**

The control action is controlled by an optional remote switch, when the remote switch is assigned to the READY/RUN selection in the setup item C27.

Remote switch ON: READY status (control action stop). The green belt flashes.

OFF: RUN status

Note: The control output in READY status is the value set in the setup item C12 "setting of output in case of PV over-range".

Auto tuning

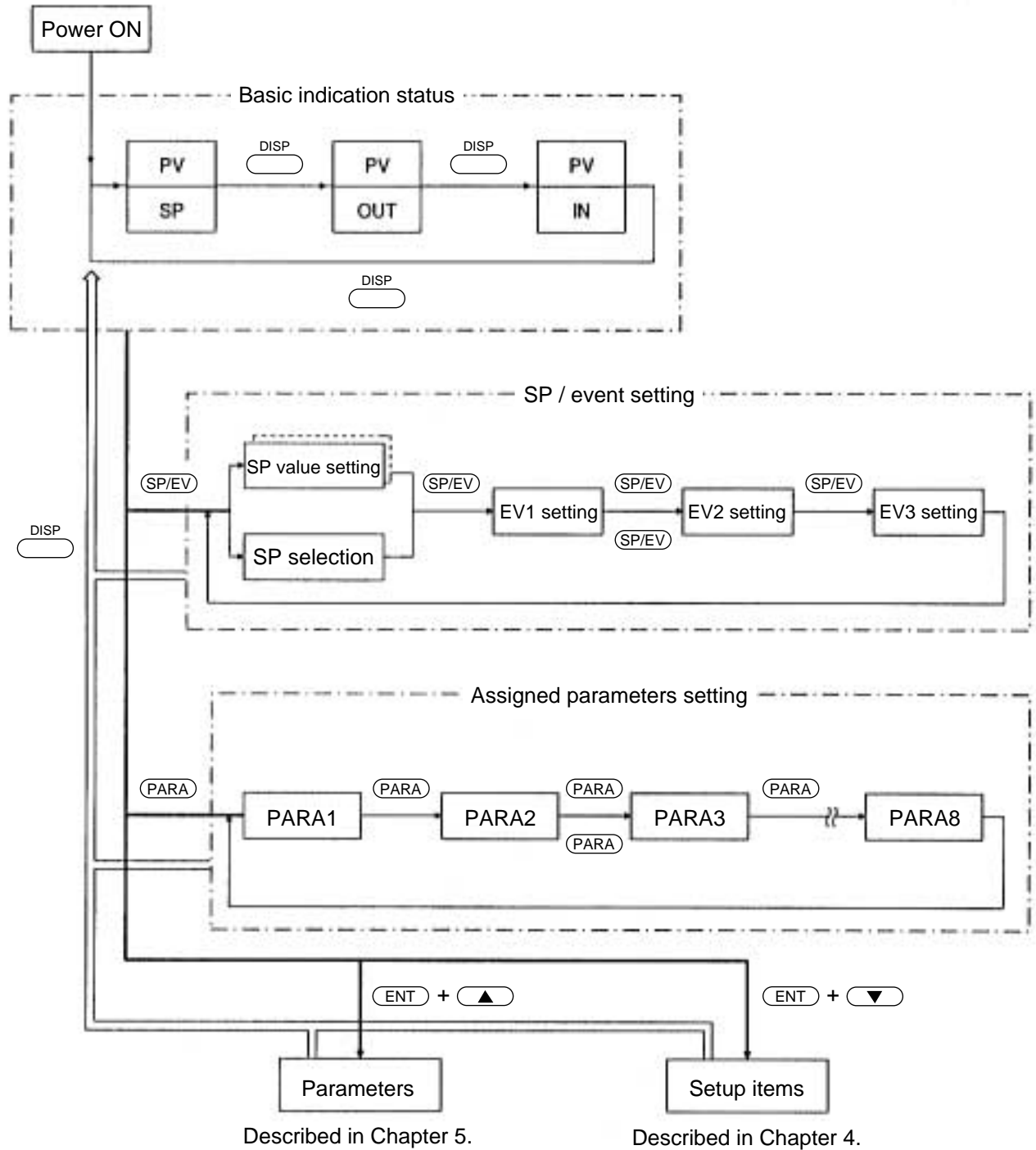

Optimum PID constants can be obtained by operating the auto tuning during a run. For the auto tuning, see page 6-12.

This instrument is transferred from the basic indication states to various kinds of setting states.

When the power supply is turned on, the instrument is set to the basic indication states. The basic indication states in also restored by pressing the **DISP** key.

## 6-2 Indicating a PV

The control value of temperature or pressure applied to this instrument is called a PV (Process Value).

When the instrument power supply is turned on, a PV is indicated in the No.1 indicator. This status is called a basic indication status.

The contents of indication may be changed after operating any key.

To indicate a PV, press the  key, and a PV will be indicated in the No.1 indicator.

### Operation Procedure

To indicate a PV Press the  key.

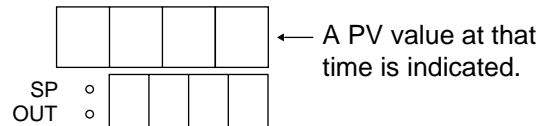

Note) If an alarm occurs, the alarm code and PV value are indicated alternately.

## 6-3 Indicating an SP

A desired value for controlling a PV is called an SP (Set Point).

When the instrument power supply is turned on, a PV is indicated in the No.1 indicator, and an SP in the No.2 indicator.

The contents of indication may be changed after pressing any key.

To indicate an SP, press the  key.

the SP LED lights and an SP is indicated in the No.2 indicator.

### Operation Procedure

To indicate an SP Press the  key.

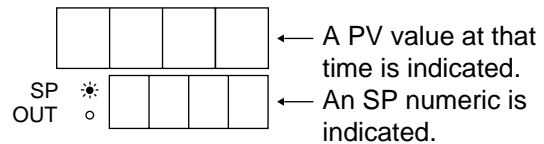

Note) Press the  key several times until the SP LED lights.

The SP LED lights.

## 6-4 Indicating the Output Value

The output value for control can be indicated. The indicating method for the output value and an example of its operation procedure are shown below.

### Operation Procedure

When PV=600°C, SP=250°C and OUT=50.0% as an example, the indication procedure is shown below.

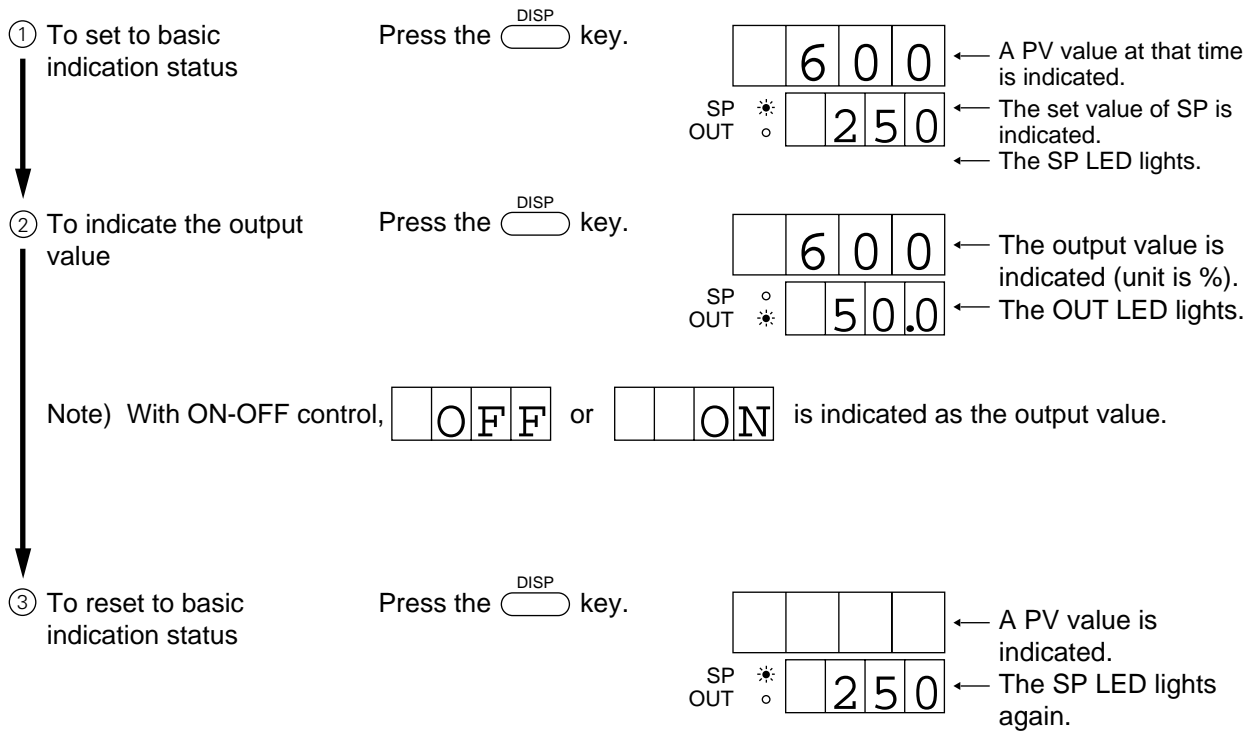

Note) When the heater breakage alarm function is provided, press the  key twice.

## 6-5 Indicating the Heater Current Value (optional)

To indicate the heater current value applied via a current transformer (CT) in a model provided with the heater breakage alarm function, follow the operation procedure given below.

### Operation Procedure

In this example, PV=600°C, SP=250°C and the heater current value=28.0 A are assumed.

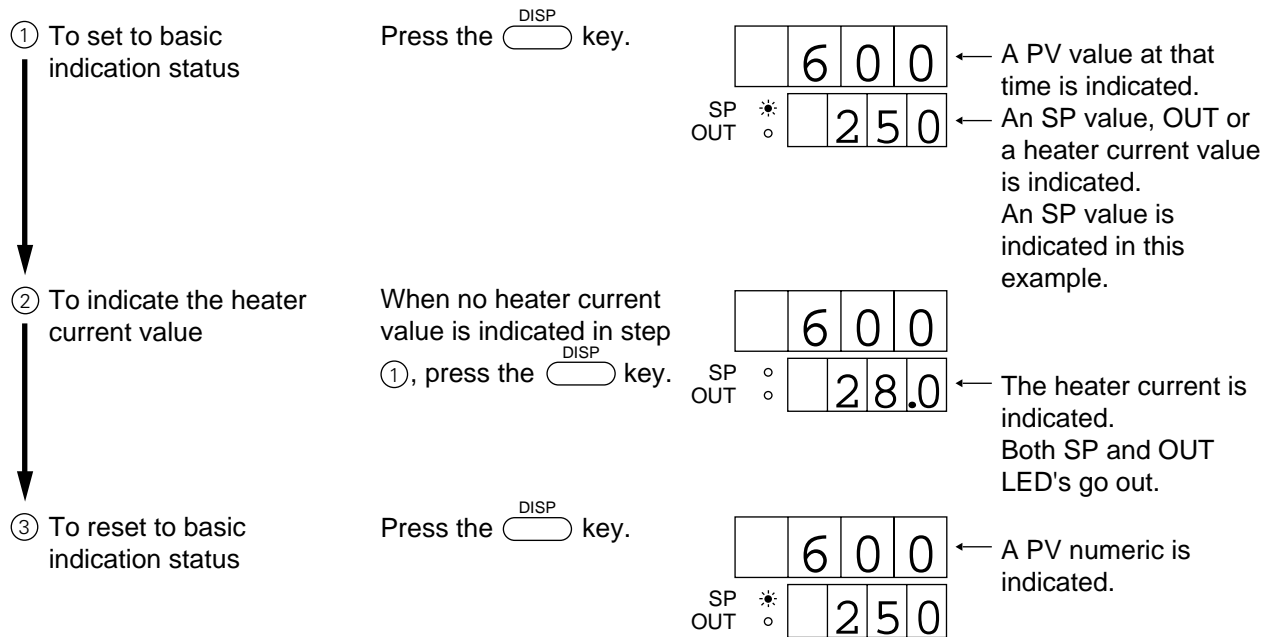

Note) The unit is A (ampere).

When the control output is off, the heater current value cannot be measured. Therefore, the last measured value in the control output on status flashes.

## 6-6 Changing an SP (with single SP)

To change an SP value of single SP, follow the operation procedure given below.

### Operation Procedure

The procedure for changing the SP from 500°C to 1000°C is shown below.

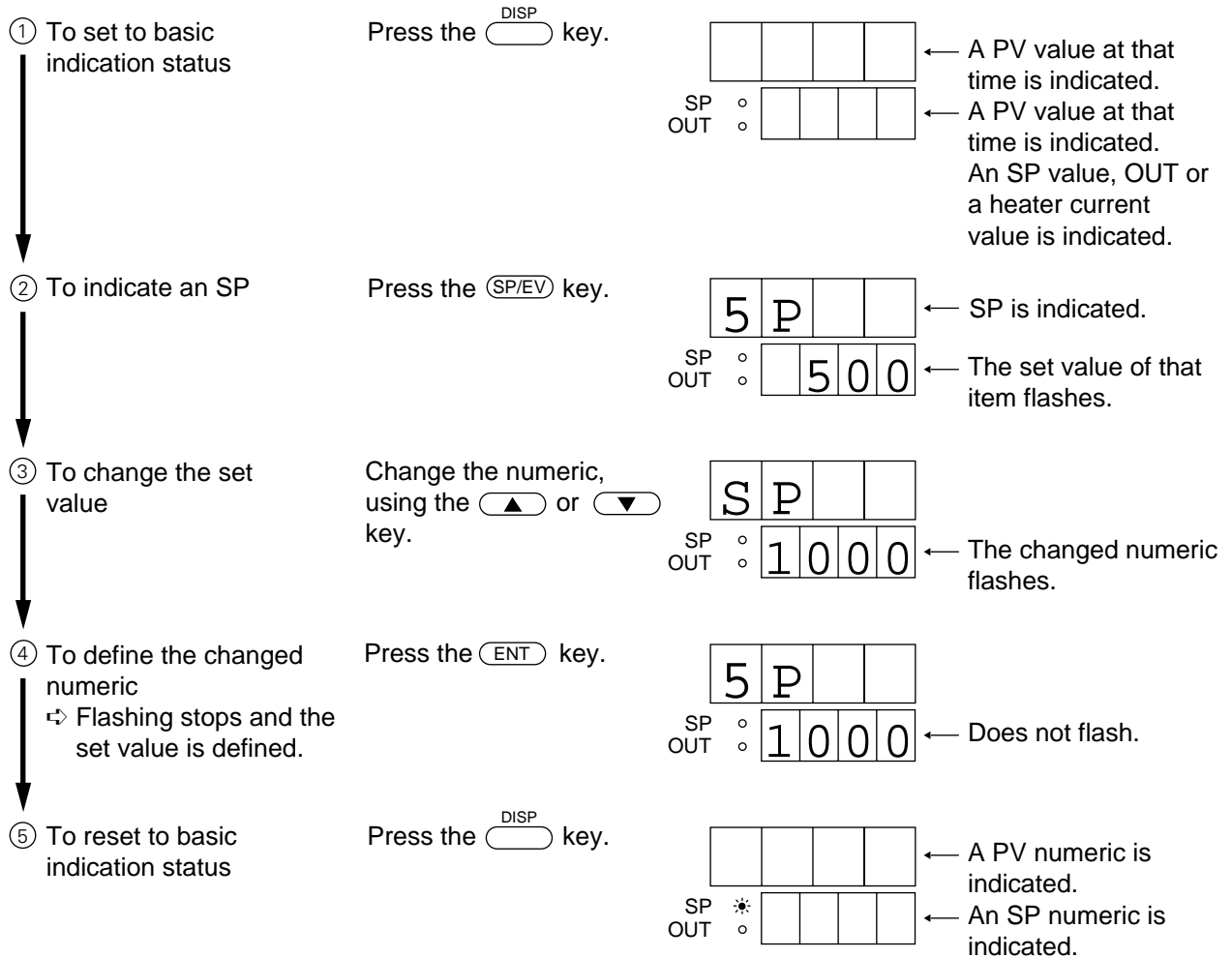

Note) With multi SP (C08 = 1), SP0 is indicated in the No.1 indicator, and its 0 flashes.  
In this case, SP selection is done.

## 6-7 Changing an SP (with multi SP)

To change an SP value of multi SP, follow the operation procedure given below. With multi SP, there are two set values SP0 and SP1.

### Operation Procedure

In this example, SP0 and SP1 have been assigned to the **PARA** key. The procedure for changing the SP0 from 250°C to 300°C is shown below.

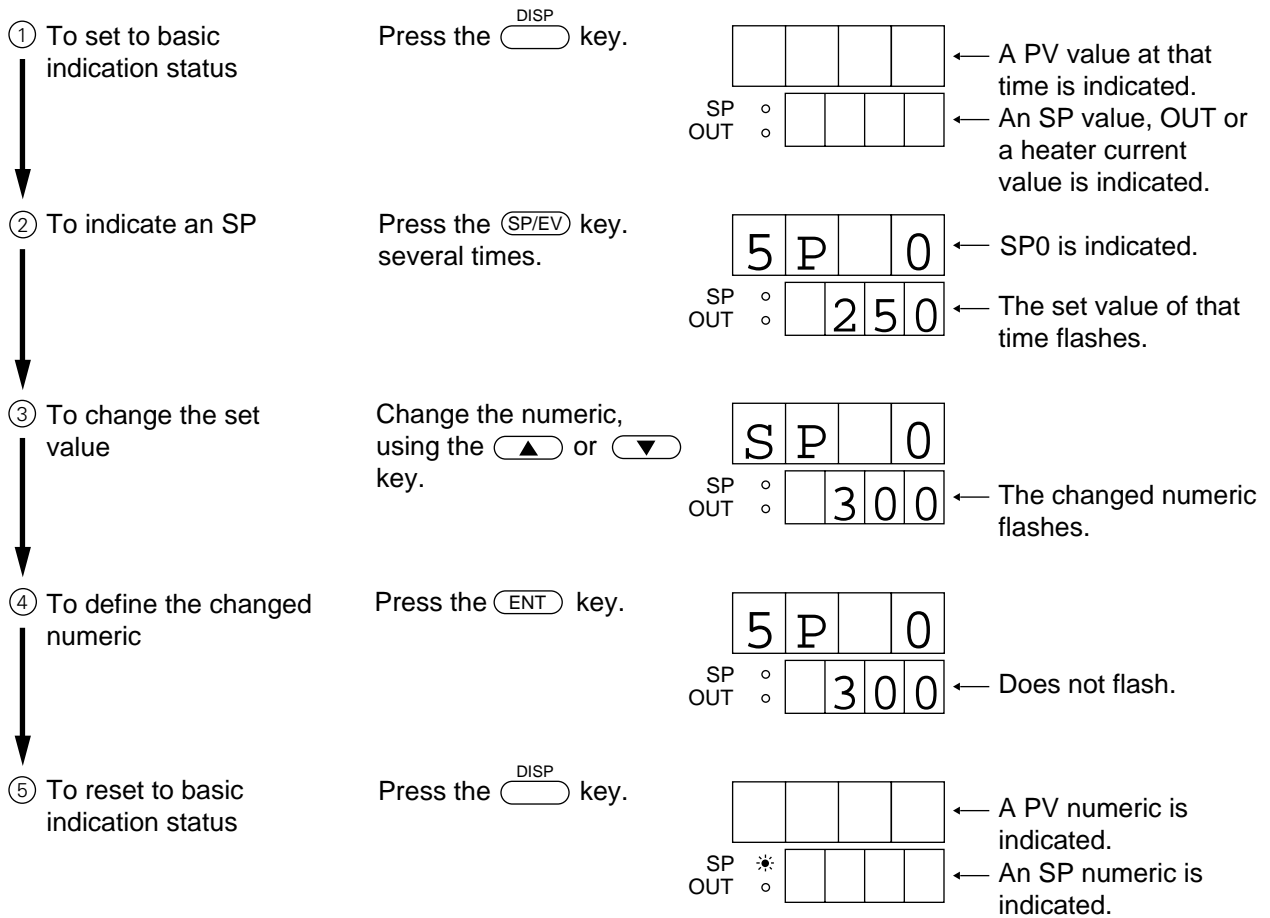



## 6-8 Selecting the SP of Multi SP

With multi SP, there are two set values SP0 and SP1. Either SP0 or SP1 can be selected.

### Operation Procedure

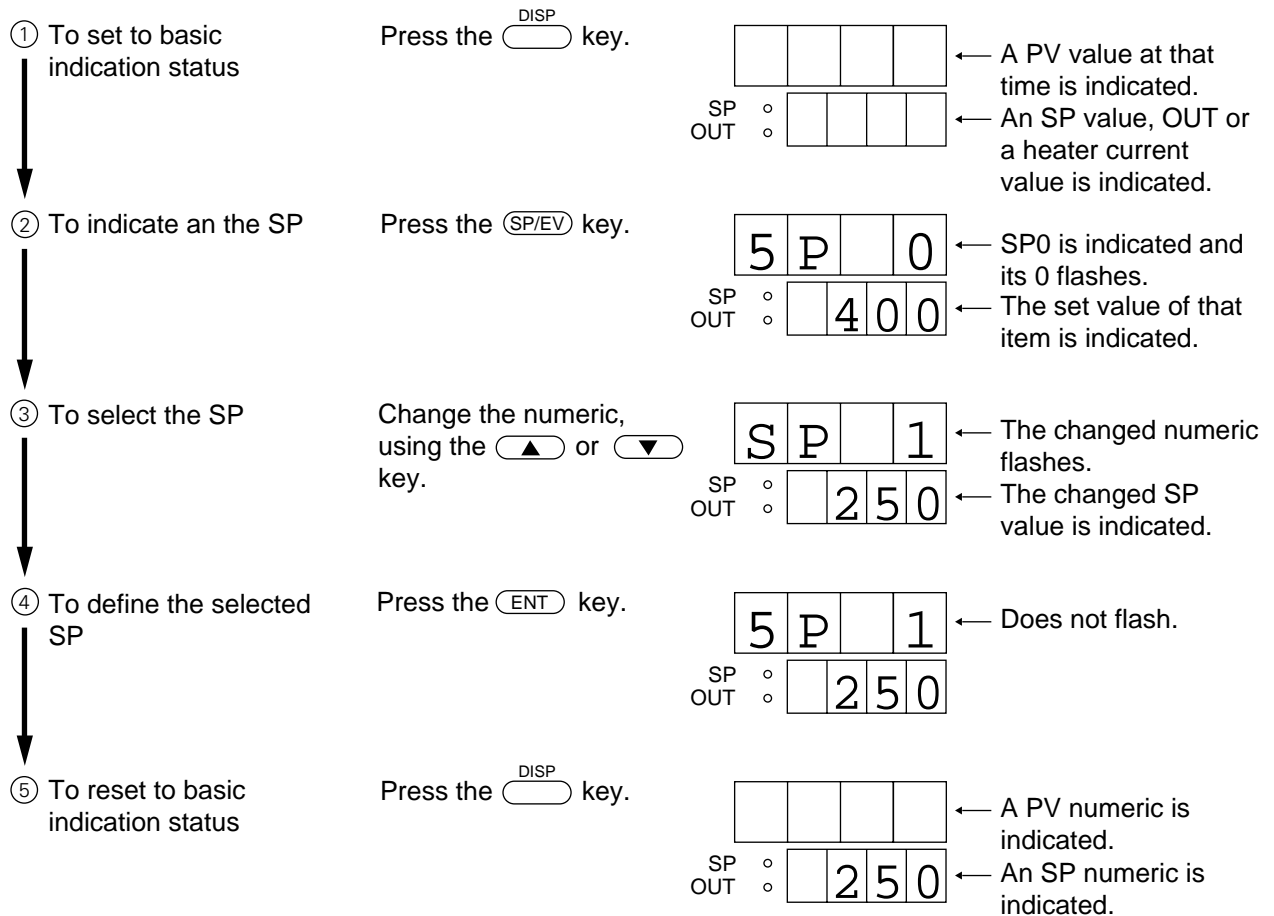
The procedure for changing SP0 (400°C) to SP1 (250°C) is given below as an example.



Note) To change the selected SP again in step ④, press the  key again.

### CAUTION

With multi SP, two groups of PID constants are prepared. SP0 corresponds to P.I.D, and SP1 to P1, I1, D1. When a remote switch (optional) is assigned to the SP selection (C27=2), this corresponding is determined by key operation with external priority given.

## 6-9 Changing the Set Value of Event (optional)

When the event (alarm function) function is provided at option, its set value (output at alarm position) can be changed.

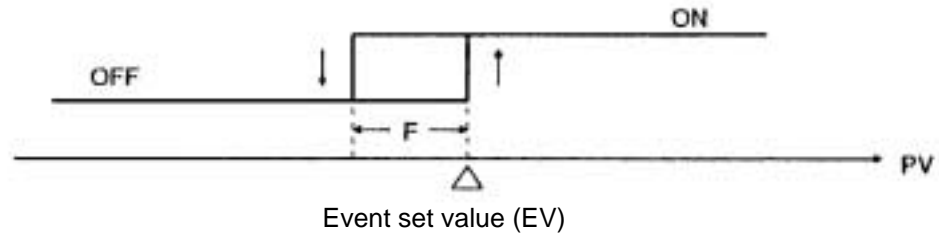





In this example, the event output is turned on, when the PV becomes higher than the event set value. The event set value is turned off when the PV is lower than the event set value (hysteresis). The procedure for changing the event set value is shown below as an example.

### Operation Procedure

The procedure for changing the event 1 from 100°C to 200°C, and the event 2 from 700°C to 800°C is shown below as an example.

<p>① To set to basic indication status</p> <p>↓</p> <p>② To indicate the event</p> <p>↓</p> <p>③ To change the set value</p> <p>↓</p> <p>④ To define the changed numeric</p> <p>↓</p> <p>⑤ To indicate the event 2</p>	<p>Press the <b>DISP</b> key.</p> <p>Press the <b>SP/EV</b> key twice.</p> <p>Press the <b>▲</b> key or <b>▼</b> key. In this example, press the <b>▲</b> key to change 100 to 200.</p> <p>Press the <b>ENT</b> key.</p> <p>Press the <b>SP/EV</b> key.</p>	<table border="0"> <tr> <td style="text-align: right;"> <table border="1" style="border-collapse: collapse;"> <tr><td> </td><td> </td><td> </td><td> </td></tr> <tr><td>SP</td><td>○</td><td> </td><td> </td></tr> <tr><td>OUT</td><td>○</td><td> </td><td> </td></tr> </table> </td> <td style="padding-left: 10px;"> <p>← A PV value at that time is indicated.</p> <p>← An SP value, OUT or a heater current value is indicated.</p> </td> </tr> <tr> <td style="text-align: right;"> <table border="1" style="border-collapse: collapse;"> <tr><td>E</td><td>1</td><td> </td><td> </td></tr> <tr><td>SP</td><td>○</td><td> </td><td> </td></tr> <tr><td>OUT</td><td>○</td><td>1</td><td>00</td></tr> </table> </td> <td style="padding-left: 10px;"> <p>← E1 is indicated.</p> <p>← Flashes.</p> </td> </tr> <tr> <td style="text-align: right;"> <table border="1" style="border-collapse: collapse;"> <tr><td>E</td><td>1</td><td> </td><td> </td></tr> <tr><td>SP</td><td>○</td><td> </td><td> </td></tr> <tr><td>OUT</td><td>○</td><td>2</td><td>00</td></tr> </table> </td> <td style="padding-left: 10px;"> <p>← Flashes.</p> </td> </tr> <tr> <td style="text-align: right;"> <table border="1" style="border-collapse: collapse;"> <tr><td>E</td><td>1</td><td> </td><td> </td></tr> <tr><td>SP</td><td>○</td><td> </td><td> </td></tr> <tr><td>OUT</td><td>○</td><td>2</td><td>00</td></tr> </table> </td> <td style="padding-left: 10px;"> <p>← Does not flash.</p> </td> </tr> <tr> <td style="text-align: right;"> <table border="1" style="border-collapse: collapse;"> <tr><td>E</td><td>2</td><td> </td><td> </td></tr> <tr><td>SP</td><td>○</td><td> </td><td> </td></tr> <tr><td>OUT</td><td>○</td><td>7</td><td>00</td></tr> </table> </td> <td style="padding-left: 10px;"> <p>← E2 is indicated.</p> <p>← Flashes.</p> </td> </tr> </table>	<table border="1" style="border-collapse: collapse;"> <tr><td> </td><td> </td><td> </td><td> </td></tr> <tr><td>SP</td><td>○</td><td> </td><td> </td></tr> <tr><td>OUT</td><td>○</td><td> </td><td> </td></tr> </table>					SP	○			OUT	○			<p>← A PV value at that time is indicated.</p> <p>← An SP value, OUT or a heater current value is indicated.</p>	<table border="1" style="border-collapse: collapse;"> <tr><td>E</td><td>1</td><td> </td><td> </td></tr> <tr><td>SP</td><td>○</td><td> </td><td> </td></tr> <tr><td>OUT</td><td>○</td><td>1</td><td>00</td></tr> </table>	E	1			SP	○			OUT	○	1	00	<p>← E1 is indicated.</p> <p>← Flashes.</p>	<table border="1" style="border-collapse: collapse;"> <tr><td>E</td><td>1</td><td> </td><td> </td></tr> <tr><td>SP</td><td>○</td><td> </td><td> </td></tr> <tr><td>OUT</td><td>○</td><td>2</td><td>00</td></tr> </table>	E	1			SP	○			OUT	○	2	00	<p>← Flashes.</p>	<table border="1" style="border-collapse: collapse;"> <tr><td>E</td><td>1</td><td> </td><td> </td></tr> <tr><td>SP</td><td>○</td><td> </td><td> </td></tr> <tr><td>OUT</td><td>○</td><td>2</td><td>00</td></tr> </table>	E	1			SP	○			OUT	○	2	00	<p>← Does not flash.</p>	<table border="1" style="border-collapse: collapse;"> <tr><td>E</td><td>2</td><td> </td><td> </td></tr> <tr><td>SP</td><td>○</td><td> </td><td> </td></tr> <tr><td>OUT</td><td>○</td><td>7</td><td>00</td></tr> </table>	E	2			SP	○			OUT	○	7	00	<p>← E2 is indicated.</p> <p>← Flashes.</p>
<table border="1" style="border-collapse: collapse;"> <tr><td> </td><td> </td><td> </td><td> </td></tr> <tr><td>SP</td><td>○</td><td> </td><td> </td></tr> <tr><td>OUT</td><td>○</td><td> </td><td> </td></tr> </table>					SP	○			OUT	○			<p>← A PV value at that time is indicated.</p> <p>← An SP value, OUT or a heater current value is indicated.</p>																																																											
SP	○																																																																							
OUT	○																																																																							
<table border="1" style="border-collapse: collapse;"> <tr><td>E</td><td>1</td><td> </td><td> </td></tr> <tr><td>SP</td><td>○</td><td> </td><td> </td></tr> <tr><td>OUT</td><td>○</td><td>1</td><td>00</td></tr> </table>	E	1			SP	○			OUT	○	1	00	<p>← E1 is indicated.</p> <p>← Flashes.</p>																																																											
E	1																																																																							
SP	○																																																																							
OUT	○	1	00																																																																					
<table border="1" style="border-collapse: collapse;"> <tr><td>E</td><td>1</td><td> </td><td> </td></tr> <tr><td>SP</td><td>○</td><td> </td><td> </td></tr> <tr><td>OUT</td><td>○</td><td>2</td><td>00</td></tr> </table>	E	1			SP	○			OUT	○	2	00	<p>← Flashes.</p>																																																											
E	1																																																																							
SP	○																																																																							
OUT	○	2	00																																																																					
<table border="1" style="border-collapse: collapse;"> <tr><td>E</td><td>1</td><td> </td><td> </td></tr> <tr><td>SP</td><td>○</td><td> </td><td> </td></tr> <tr><td>OUT</td><td>○</td><td>2</td><td>00</td></tr> </table>	E	1			SP	○			OUT	○	2	00	<p>← Does not flash.</p>																																																											
E	1																																																																							
SP	○																																																																							
OUT	○	2	00																																																																					
<table border="1" style="border-collapse: collapse;"> <tr><td>E</td><td>2</td><td> </td><td> </td></tr> <tr><td>SP</td><td>○</td><td> </td><td> </td></tr> <tr><td>OUT</td><td>○</td><td>7</td><td>00</td></tr> </table>	E	2			SP	○			OUT	○	7	00	<p>← E2 is indicated.</p> <p>← Flashes.</p>																																																											
E	2																																																																							
SP	○																																																																							
OUT	○	7	00																																																																					

<p>⑥ To change the set value</p> <p>↓</p> <p>⑦ To define the changed numeric</p> <p>↓</p> <p>⑧ To reset to basic indication status</p>	<p>Press the  key or  key. In this example, press the  key to change 700 to 800.</p> <p>Press the  key.</p> <p>Press the  key.</p>	<table border="0"> <tr> <td style="text-align: right;">E 2</td> <td style="border: 1px solid black; width: 20px; height: 20px;"></td> <td style="border: 1px solid black; width: 20px; height: 20px;"></td> <td style="border: 1px solid black; width: 20px; height: 20px;"></td> <td style="border: 1px solid black; width: 20px; height: 20px;"></td> <td></td> </tr> <tr> <td style="text-align: right;">SP</td> <td style="border: 1px solid black; width: 20px; height: 20px;"></td> <td style="border: 1px solid black; width: 20px; height: 20px; text-align: center;">8</td> <td style="border: 1px solid black; width: 20px; height: 20px; text-align: center;">0</td> <td style="border: 1px solid black; width: 20px; height: 20px; text-align: center;">0</td> <td>← Flashes.</td> </tr> <tr> <td style="text-align: right;">OUT</td> <td style="border: 1px solid black; width: 20px; height: 20px;"></td> <td style="border: 1px solid black; width: 20px; height: 20px;"></td> <td style="border: 1px solid black; width: 20px; height: 20px;"></td> <td style="border: 1px solid black; width: 20px; height: 20px;"></td> <td></td> </tr> </table> <table border="0"> <tr> <td style="text-align: right;">E 2</td> <td style="border: 1px solid black; width: 20px; height: 20px;"></td> <td style="border: 1px solid black; width: 20px; height: 20px;"></td> <td style="border: 1px solid black; width: 20px; height: 20px;"></td> <td style="border: 1px solid black; width: 20px; height: 20px;"></td> <td></td> </tr> <tr> <td style="text-align: right;">SP</td> <td style="border: 1px solid black; width: 20px; height: 20px;"></td> <td style="border: 1px solid black; width: 20px; height: 20px; text-align: center;">8</td> <td style="border: 1px solid black; width: 20px; height: 20px; text-align: center;">0</td> <td style="border: 1px solid black; width: 20px; height: 20px; text-align: center;">0</td> <td>← Does not flash.</td> </tr> <tr> <td style="text-align: right;">OUT</td> <td style="border: 1px solid black; width: 20px; height: 20px;"></td> <td style="border: 1px solid black; width: 20px; height: 20px;"></td> <td style="border: 1px solid black; width: 20px; height: 20px;"></td> <td style="border: 1px solid black; width: 20px; height: 20px;"></td> <td></td> </tr> </table> <table border="0"> <tr> <td style="border: 1px solid black; width: 20px; height: 20px;"></td> <td style="border: 1px solid black; width: 20px; height: 20px;"></td> <td style="border: 1px solid black; width: 20px; height: 20px;"></td> <td style="border: 1px solid black; width: 20px; height: 20px;"></td> <td style="border: 1px solid black; width: 20px; height: 20px;"></td> <td>← A PV numeric is indicated.</td> </tr> <tr> <td style="text-align: right;">SP</td> <td style="border: 1px solid black; width: 20px; height: 20px;"></td> <td style="border: 1px solid black; width: 20px; height: 20px;"></td> <td style="border: 1px solid black; width: 20px; height: 20px;"></td> <td style="border: 1px solid black; width: 20px; height: 20px;"></td> <td>← An SP numeric is indicated.</td> </tr> <tr> <td style="text-align: right;">OUT</td> <td style="border: 1px solid black; width: 20px; height: 20px;"></td> <td style="border: 1px solid black; width: 20px; height: 20px;"></td> <td style="border: 1px solid black; width: 20px; height: 20px;"></td> <td style="border: 1px solid black; width: 20px; height: 20px;"></td> <td></td> </tr> </table>	E 2						SP		8	0	0	← Flashes.	OUT						E 2						SP		8	0	0	← Does not flash.	OUT											← A PV numeric is indicated.	SP					← An SP numeric is indicated.	OUT					
E 2																																																								
SP		8	0	0	← Flashes.																																																			
OUT																																																								
E 2																																																								
SP		8	0	0	← Does not flash.																																																			
OUT																																																								
					← A PV numeric is indicated.																																																			
SP					← An SP numeric is indicated.																																																			
OUT																																																								





## 6-10 Changing the Set Value of PV Bias

A bias can be added to a PV to be input to this instrument.

The PV plus bias is indicated, and the internal arithmetic operation is also executed with this value.

### Operation Procedure

The procedure for changing the PV bias from 0°C to 20°C when PV=600°C is shown below as an example.

<p>① To set basic indication status</p> <p>↓</p> <p>② To indicate the parameters</p> <p>↓</p> <p>③ To indicate the PV bias</p> <p>↓</p> <p>④ To change the set value</p> <p>↓</p>	<p>Press the  key.</p> <p>Press the  key and  keys simultaneously for 3 seconds.</p> <p>Press the  key.</p> <p>Press the  key.</p>	<table border="0"> <tr> <td style="text-align: right;">6</td> <td style="border: 1px solid black; width: 20px; height: 20px;"></td> <td style="border: 1px solid black; width: 20px; height: 20px; text-align: center;">0</td> <td style="border: 1px solid black; width: 20px; height: 20px; text-align: center;">0</td> <td style="border: 1px solid black; width: 20px; height: 20px;"></td> <td>← A PV value at that time is indicated. 600°C in this example.</td> </tr> <tr> <td style="text-align: right;">SP</td> <td style="border: 1px solid black; width: 20px; height: 20px;"></td> <td style="border: 1px solid black; width: 20px; height: 20px;"></td> <td style="border: 1px solid black; width: 20px; height: 20px;"></td> <td style="border: 1px solid black; width: 20px; height: 20px;"></td> <td>← An SP value, OUT or a heater current value is indicated.</td> </tr> <tr> <td style="text-align: right;">OUT</td> <td style="border: 1px solid black; width: 20px; height: 20px;"></td> <td style="border: 1px solid black; width: 20px; height: 20px;"></td> <td style="border: 1px solid black; width: 20px; height: 20px;"></td> <td style="border: 1px solid black; width: 20px; height: 20px;"></td> <td></td> </tr> </table> <table border="0"> <tr> <td style="text-align: right;">A</td> <td style="border: 1px solid black; width: 20px; height: 20px; text-align: center;">T</td> <td style="border: 1px solid black; width: 20px; height: 20px;"></td> <td style="border: 1px solid black; width: 20px; height: 20px;"></td> <td style="border: 1px solid black; width: 20px; height: 20px;"></td> <td>← The parameter is indicated.</td> </tr> <tr> <td style="text-align: right;">SP</td> <td style="border: 1px solid black; width: 20px; height: 20px;"></td> <td style="border: 1px solid black; width: 20px; height: 20px;"></td> <td style="border: 1px solid black; width: 20px; height: 20px;"></td> <td style="border: 1px solid black; width: 20px; height: 20px;"></td> <td>← The set value of that item is indicated.</td> </tr> <tr> <td style="text-align: right;">OUT</td> <td style="border: 1px solid black; width: 20px; height: 20px;"></td> <td style="border: 1px solid black; width: 20px; height: 20px;"></td> <td style="border: 1px solid black; width: 20px; height: 20px;"></td> <td style="border: 1px solid black; width: 20px; height: 20px;"></td> <td></td> </tr> </table> <table border="0"> <tr> <td style="text-align: right;">P</td> <td style="border: 1px solid black; width: 20px; height: 20px; text-align: center;">B</td> <td style="border: 1px solid black; width: 20px; height: 20px; text-align: center;">I</td> <td style="border: 1px solid black; width: 20px; height: 20px; text-align: center;">A</td> <td style="border: 1px solid black; width: 20px; height: 20px;"></td> <td>← Pb IA is indicated.</td> </tr> <tr> <td style="text-align: right;">SP</td> <td style="border: 1px solid black; width: 20px; height: 20px;"></td> <td style="border: 1px solid black; width: 20px; height: 20px;"></td> <td style="border: 1px solid black; width: 20px; height: 20px;"></td> <td style="border: 1px solid black; width: 20px; height: 20px; text-align: center;">0</td> <td>← The set value of that item is indicated.</td> </tr> <tr> <td style="text-align: right;">OUT</td> <td style="border: 1px solid black; width: 20px; height: 20px;"></td> <td style="border: 1px solid black; width: 20px; height: 20px;"></td> <td style="border: 1px solid black; width: 20px; height: 20px;"></td> <td style="border: 1px solid black; width: 20px; height: 20px;"></td> <td></td> </tr> </table> <table border="0"> <tr> <td style="text-align: right;">P</td> <td style="border: 1px solid black; width: 20px; height: 20px; text-align: center;">B</td> <td style="border: 1px solid black; width: 20px; height: 20px; text-align: center;">I</td> <td style="border: 1px solid black; width: 20px; height: 20px; text-align: center;">A</td> <td style="border: 1px solid black; width: 20px; height: 20px;"></td> <td></td> </tr> <tr> <td style="text-align: right;">SP</td> <td style="border: 1px solid black; width: 20px; height: 20px;"></td> <td style="border: 1px solid black; width: 20px; height: 20px;"></td> <td style="border: 1px solid black; width: 20px; height: 20px;"></td> <td style="border: 1px solid black; width: 20px; height: 20px; text-align: center;">0</td> <td>← The numeric flashes.</td> </tr> <tr> <td style="text-align: right;">OUT</td> <td style="border: 1px solid black; width: 20px; height: 20px;"></td> <td style="border: 1px solid black; width: 20px; height: 20px;"></td> <td style="border: 1px solid black; width: 20px; height: 20px;"></td> <td style="border: 1px solid black; width: 20px; height: 20px;"></td> <td></td> </tr> </table>	6		0	0		← A PV value at that time is indicated. 600°C in this example.	SP					← An SP value, OUT or a heater current value is indicated.	OUT						A	T				← The parameter is indicated.	SP					← The set value of that item is indicated.	OUT						P	B	I	A		← Pb IA is indicated.	SP				0	← The set value of that item is indicated.	OUT						P	B	I	A			SP				0	← The numeric flashes.	OUT					
6		0	0		← A PV value at that time is indicated. 600°C in this example.																																																																					
SP					← An SP value, OUT or a heater current value is indicated.																																																																					
OUT																																																																										
A	T				← The parameter is indicated.																																																																					
SP					← The set value of that item is indicated.																																																																					
OUT																																																																										
P	B	I	A		← Pb IA is indicated.																																																																					
SP				0	← The set value of that item is indicated.																																																																					
OUT																																																																										
P	B	I	A																																																																							
SP				0	← The numeric flashes.																																																																					
OUT																																																																										

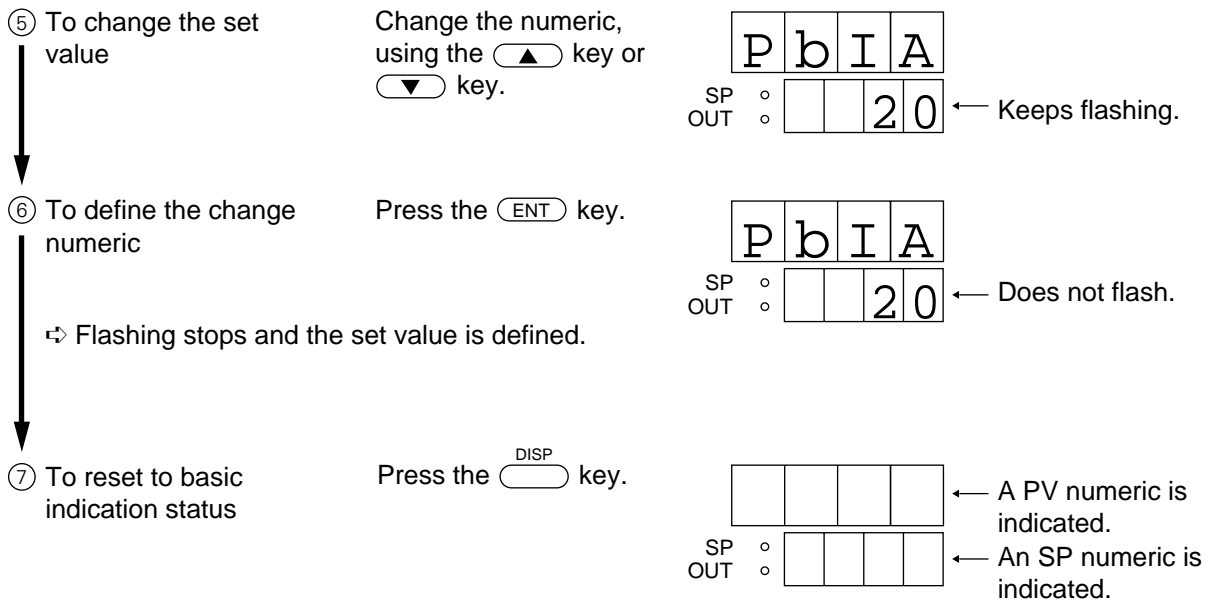

Note) The bias can be added or subtracted.  
When subtracting the bias, set a negative numeric value.

## 6-11 Changing Various Parameters

(1) To start the auto tuning assigned to the key.

### CAUTION

Caution in using the auto tuning:

When the auto tuning is executed, the control action is interrupted, and optimum PID constants are found by repeating the output of 0 to 100% several times.

If the controlled system is affected adversely by the output change of 0 to 100%, the auto tuning must not be used.

**Operation Procedure**

The procedure for starting the auto tuning when At has been assigned to the (PARA) key is described below.

① To set to basic indication status

Press the  key.

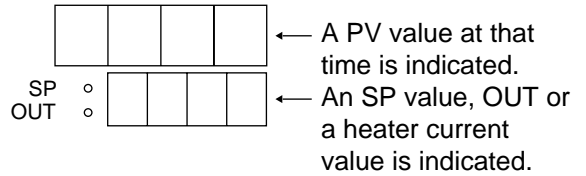

② To indicate the parameter

Press the  key.

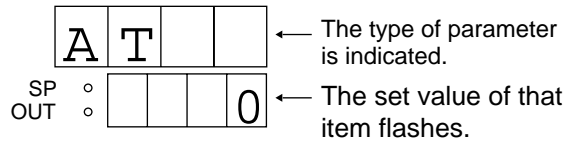

Note) Repeat pressing the  key several times until At is indicated in the No.1 indicator.

③ To change the set value

Press the  key to indicate 1 in the No.2 indicator.

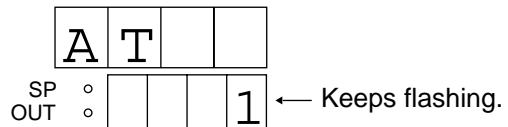

Note) When 1 is indicated in the No.2 indicator from the beginning, nothing needs to be done.

④ To define the changed numeric

Press the  key.

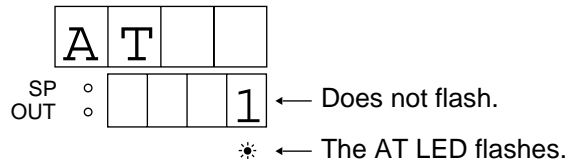

⇔ Flashing stops, and the set value is defined. The AT LED flashes, and the auto tuning starts.

⑤ To reset to basic indication status

Press the  key.

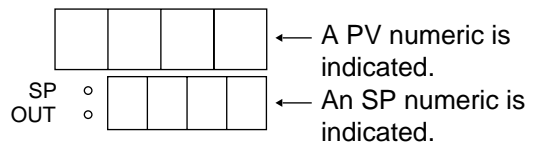

Note) When the auto tuning ends, the AT LED goes out. The PID value found is written automatically in this instrument, and it starts running.

- Note 1: Auto tuning does not function normally if it is not connected to a controlled system.
- Note 2: Optimum PID values cannot always be obtained in certain controlled systems. In such a case, set the PID values manually.
- Note 3: During auto tuning operation, hunting may occur in the controlled system. If hunting is not desirable, set PID values manually.
- Note 4: The time required for tuning depends upon the control system.
- Note 5: With multi SP, the values obtained by auto tuning are written to the PID group corresponding to the present set SP.

### One Point Memo

Auto tuning is provided to automatically obtain optimum PID values (Proportional band) (Integral time) and (Derivative time) by measuring control systems. This auto tuning can be operated during the steady-state operation as well as at start-up time.

For the PID values employed during the steady-state operation, it is recommended to obtain these values by operating the auto tuning at the same time (during steady-state operation).

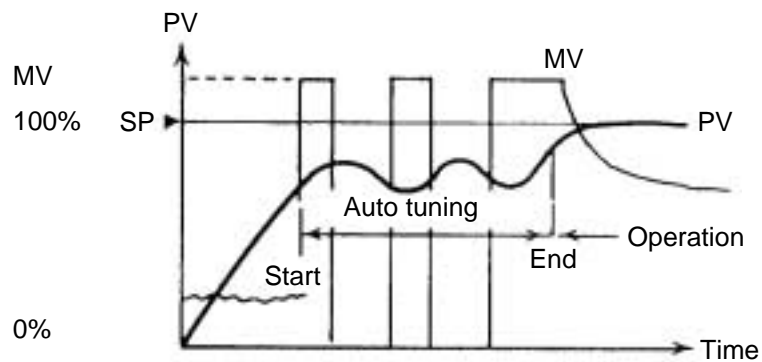



(3) To change PID values

When no PID values have been assigned to the ( PARA ) key, change them in accordance with para 5-2 “Basic parameter operation”.

When the PID values have been assigned to the ( PARA ) key, they can be changed by operating the ( PARA ) key.

**Operation Procedure**

The procedure for changing P=5.0 assigned to the ( PARA ) key to P=5.5 is shown below.

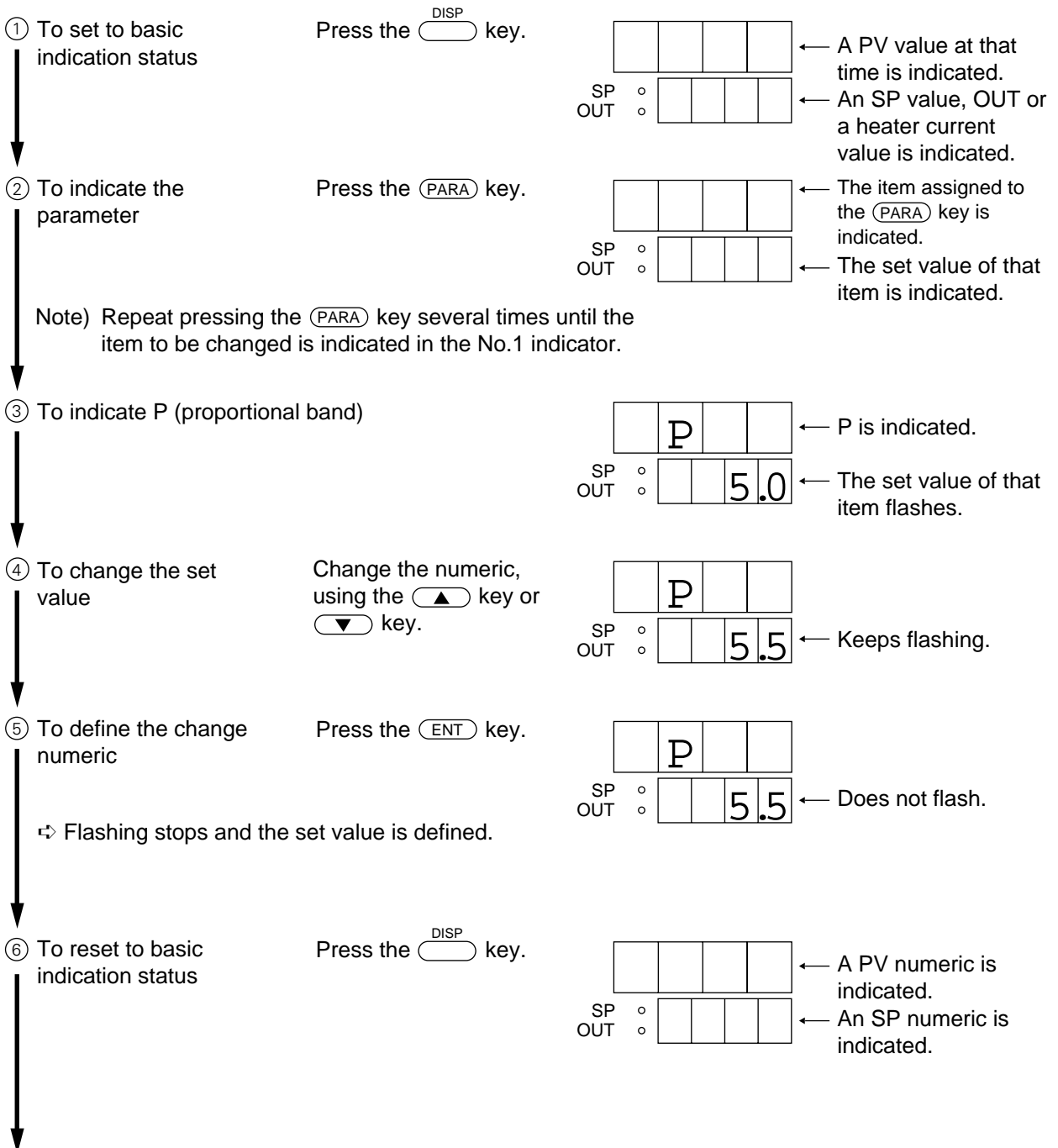

(4) To change the oL and oH (lower and upper limits of manipulated variable) values  
 When no oL and oH values have been assigned to the ( PARA ) key, change the set values in accordance with para 5-2 “Basic parameter operation”.

When the oL and oH values have been set to the ( PARA ) key, the set values can be changed by operating the ( PARA ) key.

**Operation Procedure**

The procedure for changing OL1=0 assigned to the ( PARA ) key to OL1=10 is shown below.

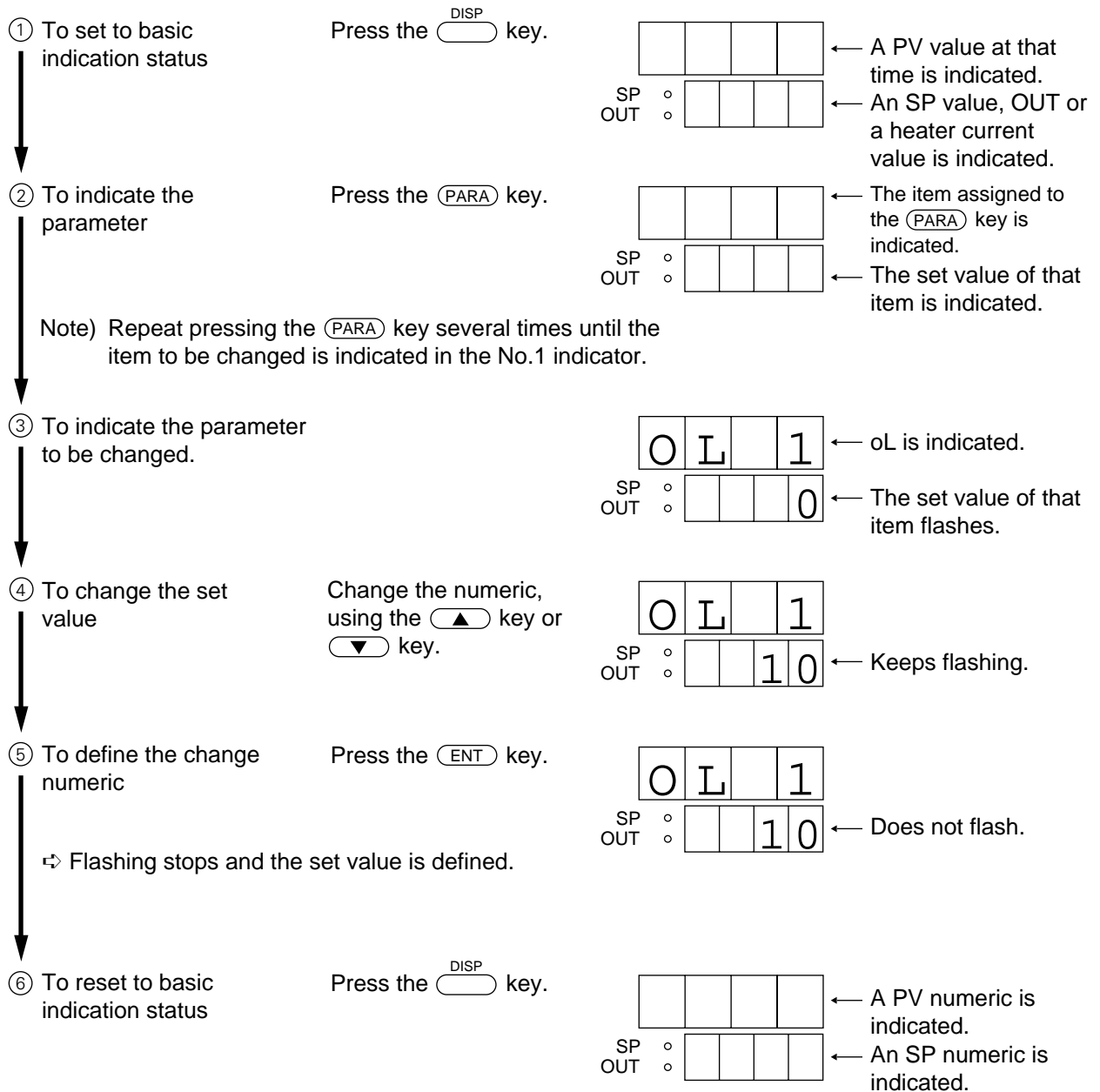

(5) To change the rE manual reset value

When the value of rE manual reset is not assigned to the (PARA) key, change the set value in accordance with para 5-2 “Basic parameter operation”.

When this value has been assigned to the (PARA) key, the set value can be changed by operating the (PARA) key.

**Operation Procedure**

The procedure for changing rE=50 assigned to the (PARA) key to rE=30 is shown below.

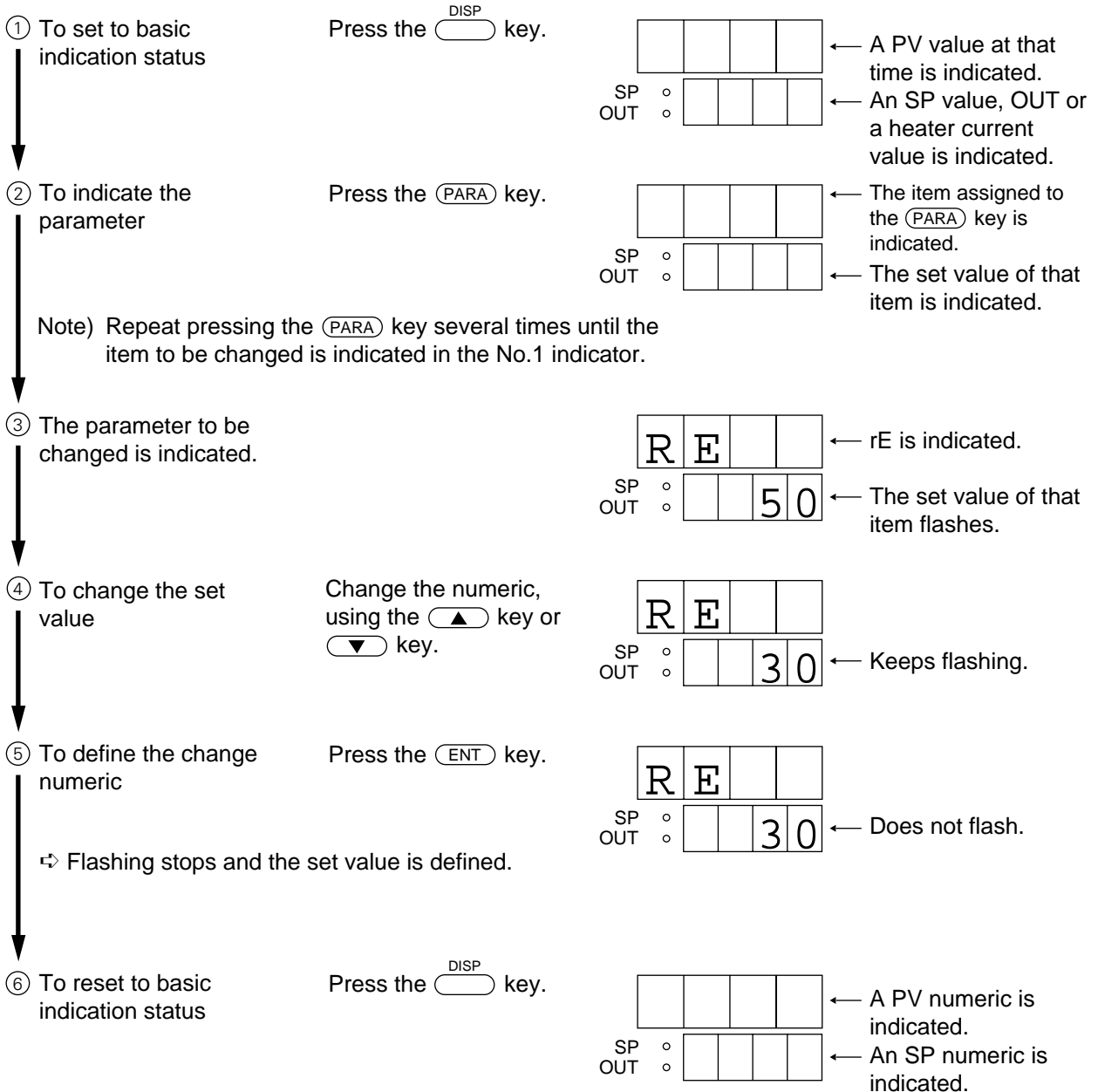

Note) The rE can be set when I = 0 and P ≠ 0.

(6) To change the diFF differential value

When no diFF differential value has not been assigned to the (PARA) key, change the set value in accordance with para 5-2 “Basic parameter operation”.

When the diFF differential value has been assigned to the (PARA) key, the set value can be changed by operating the (PARA) key.

**Operation Procedure**

The procedure for changing the diFF=5 assigned to the (PARA) key to diFF=10 is shown below.

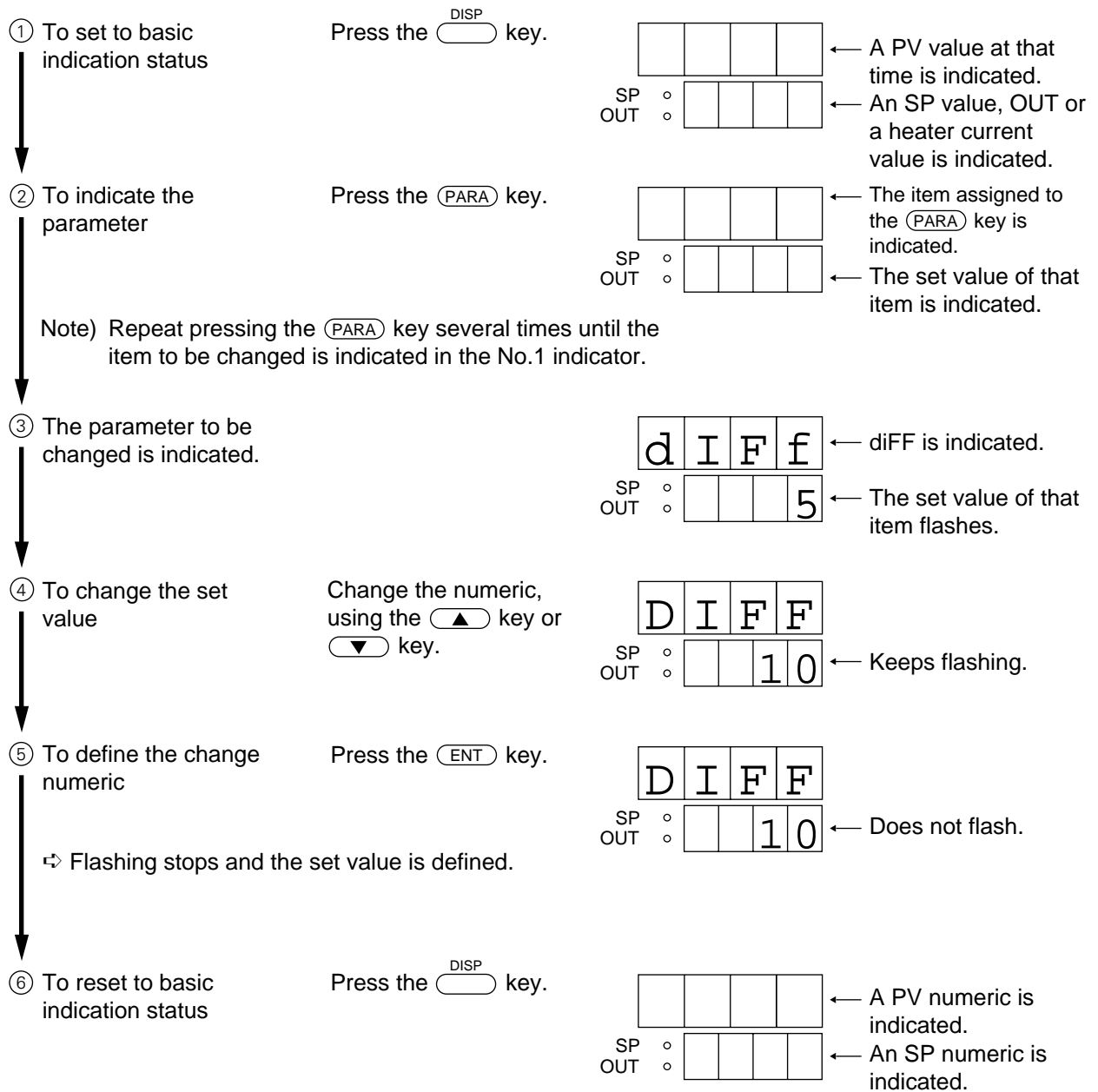

Note) The diFF can be set when P = 0.  
 With the diFF 1, D I F 1 is indicated.

(7) To change the HyS event hysteresis value

When no HyS event hysteresis value has been assigned to the (PARA) key, change the set value in accordance with para 5-2 “Basic parameter operation”.

When the HyS event hysteresis value has been assigned to the (PARA) key, the set value can be changed by operating the (PARA) key.

**Operation Procedure**

The procedure for changing the HyS1=5 assigned to the (PARA) key to HyS1=10 is shown below.

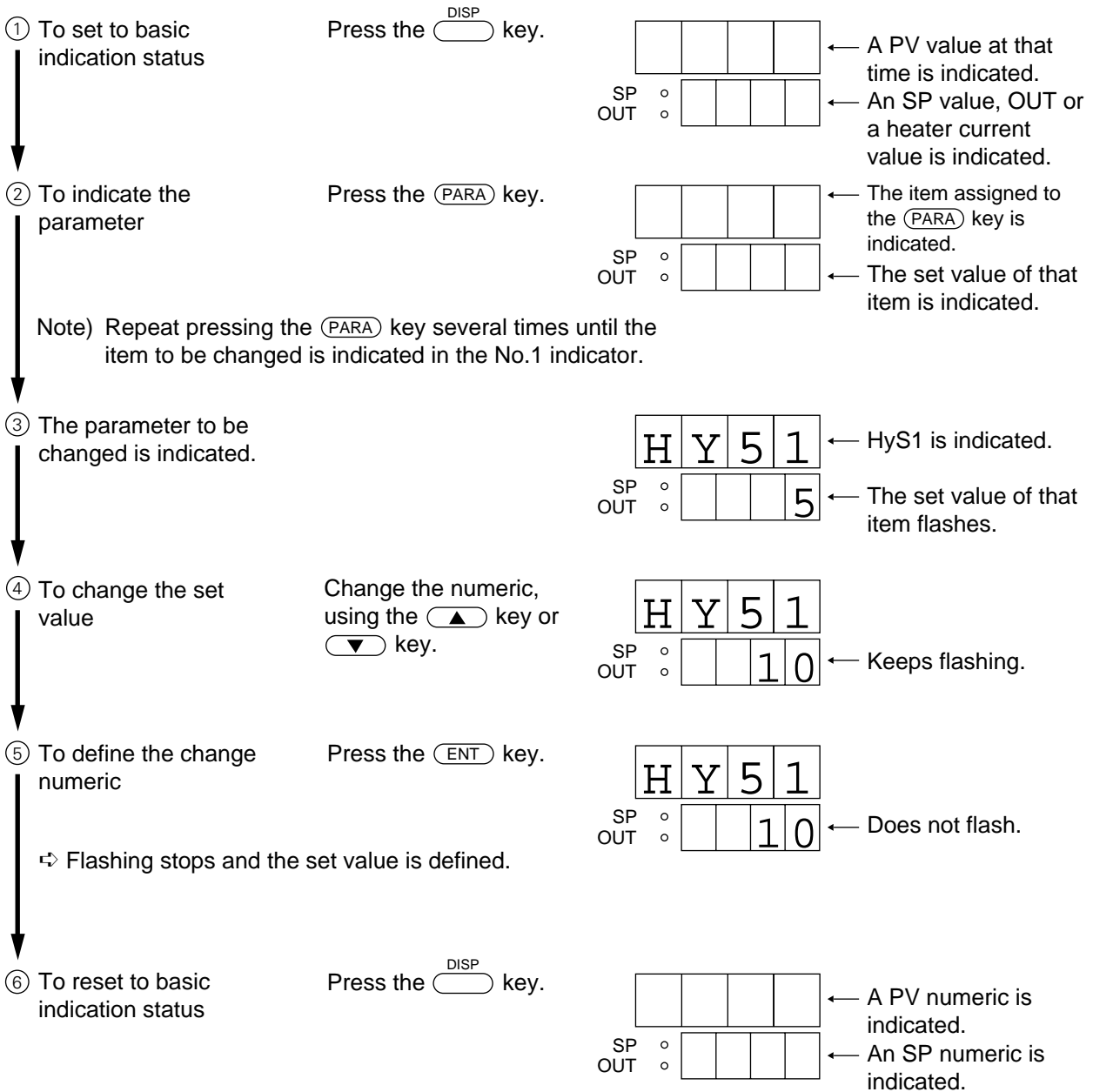

# Chapter 7 TROUBLESHOOTING

## 7-1 Alarms Indication

This instrument always executes PV input check, or self-diagnosis. If a problem is detected, the instrument indicates an alarm code on the No.1 indicator.

The No.1 indicator alternately indicates the display (such as PV) before the occurrence of the alarm and the alarm code.

Note: No alarm code is indicated on the No.1 indicator during setup operation.

Example of indication:

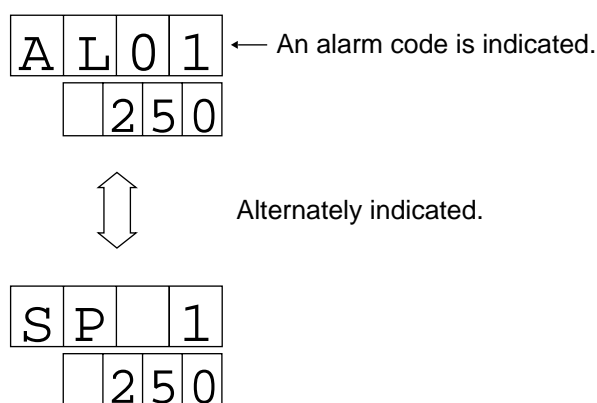

## 7-2 Alarm Codes Table

Indication	Problem description	Measures
<b>AL01</b>	PV input exceeds +10% of the range (Over-range).	Check the sensor and wiring. Check the PV range.
<b>AL02</b>	PV input is less than -10% of the range (Under-range).	Check the sensor and wiring. Check the PV range.
<b>AL03</b>	C line input error during resistance thermometer input. CJ input error during thermometer input.	Check C line wiring. Contact a YH service person for repair.
<b>AL70</b>	A/D converter trouble	Contact a YH service person for repair.
<b>AL91</b>	Loader communication message is not correct.	Check cable connection.
<b>AL96</b>	Internal communication parameter error.	Reset by communication or key input operation.
<b>AL97</b>	Parameter error	Reset.
<b>AL98</b>	Adjusting data error	Reset.

## 7-3 Heater Breakage Alarm

Heater breakage can be detected by connecting a current transformer with a model provided with the heater breakage alarm function.

To use the heater breakage alarm, set the code 19 (heater breakage alarm) in the setup items C24 to C26 (event type).

The setting range of the heater breakage alarm is 0.0 A to 50.0 A, and it can be set by the SP/EV key.

Event setting = {(heater current value at control output ON) + (heater current value at control output OFF)}/2 (A)

The hysteresis can be set with a parameter.

Hysteresis  $\leq$  [(heater current value at control output ON) – (heater current value at control output OFF)}/2] – 0.6 (A)

The model QN206A (5.8 mm dia.) and QN212A (12 mm dia.) current transformers are available at option.

An equivalent current former can be used so far as its secondary coil is wound 800 turns.

Connect the CT to the CT IN terminals of this instrument.

### CAUTION

- Connect the heater wire through the current transformer (once only).
- The terminal position differs by model. Check the label mounted on the side panel of this instrument.

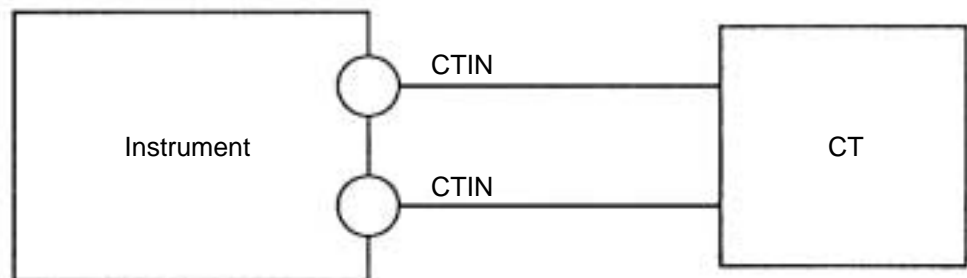

Note 1: The heater breakage event output is not locked (latched), so that its output turns on when event output conditions are satisfied, and the output turns off when these conditions are not satisfied.

Note 2: The heater breakage event can be added to either relay output (model 0D) or voltage output (model 6D). The output must be turned on longer than 200 ms during heater current measurement. Measurement cannot always be done if the output on-time is shorter than specified above. In such a case, the last measured value flashes.

Note 3: This is not applicable to a 3-phase heater.

Note 4: This is not applicable to the phase control.

Note 5: Do not flow any current exceeding 50.0 A into the current transformer. Otherwise, there is a danger of damage to the current transformer.

## 7-4 Other Troubles

When a key-in operation is not acceptable.

→ If a set value can be indicated but cannot be changed, the instrument is set to key lock status.

Set the setup item C01 “key lock” to 0.

For the release of key lock, see para 4-3 “Basic setup operation”.

When diFF (differential) cannot be set.

→ P is not 0.

The diFF can be set only when P=0.

When rE (manual reset) cannot be set.

→ I is not 0 and P is 0.

The rE can be set only when I=0, and P≠0.

This page left intentionally blank

---

# Chapter 8 SPECIFICATIONS

## 8-1 Model Number Configuration



C 2 \* \* \* \* \* \* \* \* \*

Example: C 2 0 6 D A 0 0 6 T 1









No.	Model number	Contents
<b>I</b>	Basic model No.	C20 Digital indicating controller, mask size 48 mm x 96 mm C21 Digital indicating controller, mask size 96 mm x 96 mm
<b>II</b>	Output type control mode	0D 0D Relay output, time proportional PID control/on-off control 6D 6D Voltage output, time proportional PID control/on-off control 5G 5G Current output, continuous PID control
<b>III</b>	Power voltage	A0 85 to 264V ac, 50/60 Hz AZ 85 to 264V ac, 50/60 Hz apply to RT50 D0 21.6 to 26.4V dc DZ 21.6 to 26.4V dc apply to RT50
<b>IV</b>	Option	00 to 10 See pages 8-2.
<b>V</b>	Additional functions	O Standard product T Tropical treatment K Anti-sulfidization treatment Z Correspondence to Zener barriers D Data attachment B Tropical treatment + inspection certificate provided L Anti-sulfidization treatment + inspection certificate provided E Correspondence to Zener barriers G Tropical treatment + correspondence to Zener barriers F Anit-sulfidization treatment + correspondence to Zener barriers Q Tropical treatment + correspondence to Zener barriers + inspection certificate provided P Anit-sulfidization treatment + correspondence to Zener barriers + inspection certificate provided Y Complying with the traceability certification
<b>VI</b>	Technical revision No.	1

• Options (Additional functions)







- EV1, EV2, EV3: Event
- CT: Current transformer input
- AUX: Auxiliary output
- RS-485: Communication (RS-485)
- RS-232C: Communication (RS-232C)
- RSW: Remote switch
- : Function supported
- : Function not supported
-  : Can be selected on RT-50-compatible models.
-  : Can not be selected on RT-50-compatible models.
- X: No relevant catalog No.

**C20 (48 x 96)**

No.	Additional functions							Application type		
	EV1	EV2	CT*	AUX	RS-485	RS-232C	RSW	0D	6D	5G
00	—	—	—	—	—	—	○			
01	○	○	—	—	—	—	○			
02	○	—	—	—	○	—	○			
03	○	—	—	—	—	○	○			
04	—	—	—	○	○	—	○			
05	—	—	—	○	—	○	○			
06	○	○	—	○	—	—	○			
07	○	○	○	—	—	—	○			X
08	○	—	○	○	—	—	○			X
09	○	—	○	—	○	—	—	X		X
10	○	—	○	—	—	○	○	X		X

\* When CT input is set to ON, the heater burnout alarm can be set to event operation.

**C21 (96 x 96)**

No.	Additional functions								Application type		
	EV1	EV2	EV3	CT*	AUX	RS-485	RS-232C	RSW	0D	6D	5G
00	—	—	—	—	—	—	—	○			
01	○	○	—	—	—	—	—	○			
02	○	○	—	—	○	—	—	○			
03	○	○	—	—	○	○	—	○			
04	○	○	—	—	○	—	○	○			
05	○	○	○	○	○	—	—	○			
06	○	○	○	○	—	○	—	○			
07	○	○	○	○	—	—	○	○			
08	○	○	—	○	○	○	—	○			X
09	○	○	—	○	○	—	○	○			X

\* When CT input is set to ON, the heater burnout alarm can be set to event operation.  
CT input is not provided for Nos. 05, 06 and 07 on the 5G model.

---

**ATTACHMENTS**

- Mounting bracket: 81405411-001 (1 set)
- Unit indicating label: N3132

**OPTIONS**

- Current transformer (CT): QN206 A (5.8 mm dia.)  
QN212 A (12 mm dia.)
- Hard dustproof cover: 81446083-001 (for C21)  
81446082-001 (for C20)
- Soft dustproof cover: 81446087-001 (for C21)  
81446086-001 (for C20)
- Terminal cover: 81446084-001 (for C21)  
81446088-001 (for C20)

## 8-2 Specifications

### PV Input

Type of input:	See the input range table.
Selection of the input type:	Can be selected. See “Input Ranges” table.
°C °F selection:	With T/C and RTD.
Range setting:	Range can be set by contracting it to 1/4 of the original range width.  Programmable range, with linear input (Possible by scaling)
Setting of decimal point:	With the linear input, decimals can be freely set.  With temperature inputs, setting is possible in certain ranges, to one decimal point. (See the input range table on page Appendix-5)
Input sampling cycle:	500 ms.
Indicating accuracy:	$\pm 0.3\%$ FS $\pm 1$ digit (Specified by input conversion under standard conditions.) The accuracy of B thermocouples is not specified lower than 260°C (500°F).

### T/C input (under operating conditions)

Input current:	0.13 $\mu$ A (Flows from + terminal.)
Input circuit failure indication:	Upscale + AL01

### RTD input (under operating conditions)

Input bias current:	1 mA (Flows from terminal A.)
Input circuit failure indication:	When the resistor or A line is broken ..... Upscale +AL 01 When B line is broken ..... Down scale + AL02, 03 When C line is broken ..... Undefined indication + AL03 When A and B lines are broken ..... Upscale + AL01, 03 When B and C lines are broken ..... Upscale + AL01, 03 When A and C lines are broken ..... Upscale + AL01, 03 When A, B, and C lines are broken .... Upscale + AL01, 03

### Linear voltage input (under operating conditions)

Input bias current:	0.3 $\mu$ A (Flows into + terminal.)
Input circuit failure indication:	Down scale +AL02

### Linear current input (under operating conditions)

Receiving resistance:	100 $\Omega$
Input circuit failure indication:	Down scale + AL02 (A 0 to 20 mA input circuit failure is not detectable.)

Max. input current/voltage: Max. input current 24 mA dc  
 Max. input voltage 2.4V dc  
 Normal operation will no longer be possible if these values are exceeded.

Absolute max. input ratings: Current: 50 mA dc  
 Voltage: 5V dc  
 The “absolute max. ratings” are current and voltage ratings that can be applied to input terminals without any deterioration in characteristics or mechanical breakdown. Note that these are not ranges of assured controller operation.

### Remote switch input (RSW) (under operating conditions)

No. of channels: 1  
 Input type: No-voltage contact or open collector  
 Off- terminal voltage:  $5 \pm 1$  V  
 Turn-on current:  $5 \pm 2$  mA (A current flowing to the contact)  
 Allowable contact resistance: ON Lower than 100  $\Omega$   
 OFF Upper than 100 k $\Omega$   
 Allowable residual voltage at open collector ON: 1.2 V max.  
 Allowable leakage current at open collector OFF: 0.1 mA max.  
 Minimum hold time: 400 ms

### Current transformer input H.B. (under operating condition)

Input object: Current transformer No. of coil turns ..... 800 turns  
 Option QN 206A (Hole diameter 5.8 mm)  
 or option QN 212A (Hole diameter 12 mm)  
 Current value indicating accuracy:  $\pm 5\%$  FS  $\pm 1$  digit or less  
 Indicating resolution: 0.3 A  
 Maximum measuring heater current: 50 A  
 Waiting period for output on stabilization:  
 Longer than 100 ms, but less than 200 ms  
 Input sample cycle: 100 ms (on time excluding the waiting period for output on stabilization)

### Control output

#### Relay output (0D)

Control action: Time proportional PID, PD + MR, or on-off.  
 Output type: SPDT relay output  
 Relay contact rating: 250V ac, 30V dc 5 A (Resistive load)  
 Electrical life or relays: More than 100,000 times  
 Minimum on-off time: Longer than 250 ms

**Voltage output (6D)**

Control action:	Time proportional PID, PD + MR, or on-off
Output voltage (open time):	22.5V dc $\pm$ 15% (under operating conditions)
Internal resistance:	1.1 k $\Omega$ $\pm$ 10%

**Current output (5G)**

Control action:	Current proportional PID or PD + MR
Output type:	4 to 20 mA dc current output
Allowable load resistance:	600 $\Omega$ max. (under operating conditions)
Output accuracy:	$\pm$ 0.2% FS max. (under operating conditions)
Output current range:	2.4 mA to 21.6 mA
Output update cycle:	500 ms
Output response time:	120 ms (90% response)
Voltage at terminal open:	26V dc max.

**Event output (EV 1 to 3)**

No. of channels:	0 to 3 (Depends upon models.)
Output type:	SPST relay output
Relay contact rating:	250V ac, 30V dc, 5 A
Output update cycle:	500 ms
Electrical life of relays:	More than 100,000 times

**Auxiliary output (AUX)**

Output type:	4 to 20 mA dc current output
Output contents:	PV, SP, MV (Manipulated Variables)
Allowable load resistance:	600 $\Omega$ max. (under operating conditions)
Output accuracy:	$\pm$ 0.2% FS max. (under standard conditions)
Voltage at terminal open:	26V dc max.

**Input-output isolation**

The isolation between input and output signals is illustrated below. Those bounded by a solid line are isolated from others. Those bounded by a dotted line are not isolated.

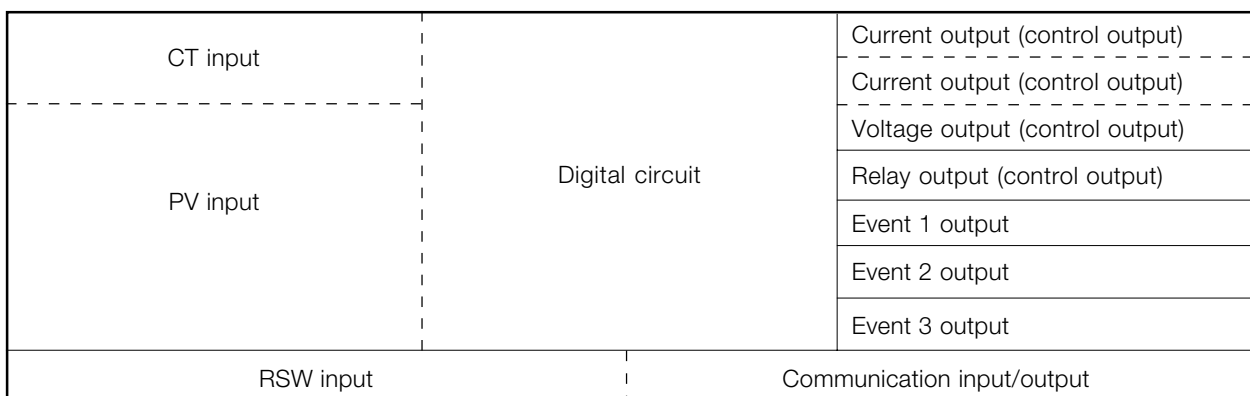

**Environmental conditions**

Standard conditions

Ambient temperature:	23 $\pm$ 2°C
Ambient humidity:	60 $\pm$ 5%RH
Power voltage (AC models):	105V ac $\pm$ 1%
Power frequency (AC models):	50/60 Hz $\pm$ 1 Hz
Power voltage (DC models):	24V dc $\pm$ 5%
Vibration resistance:	0 m/s <sup>2</sup>
Shock resistance:	0 m/s <sup>2</sup>
Mounting angle:	(Reference level) $\pm$ 3°

**Operating conditions**

Ambient temperature:	0 to 50°C (0 to 40°C during gang-mounting)
Ambient humidity:	10 to 90%RH
Power voltage (AC models):	85 to 264V ac
Power frequency (AC models):	50/60 $\pm$ 2 Hz
Power voltage (DC models):	21.6 to 26.4V dc
Vibration resistance:	0 to 2 m/s <sup>2</sup> (10 to 60 Hz, in X, Y, Z directions for 2 h each)
Shock resistance:	0 to 9.8 m/s <sup>2</sup>
Mounting angle:	(Reference level) $\pm$ 10°

**Transportation and shortage conditions**

Ambient temperature:	-20 to +70°C
Cold resistance:	-20°C +48 Hrs.
Heat resistance:	78°C 48 Hrs.
Ambient humidity:	10 to 95%RH
Vibration resistance:	0 to 4.9 m/s <sup>2</sup> (10 to 60 Hz, in X, Y, Z directions for 2 h each)
Shock resistance:	0 to 490 m/s <sup>2</sup> (3 times vertical %, when packaged.)
Package drop test:	Drop height 60 cm (Free drop from one corner, 3 edges, and 6 faces)

**Other specifications**

Rated power voltage (AC models):	100 to 240V ac
Rated power voltage (DC models):	24V dc
Insulation resistance:	50 M $\Omega$ min. between case or GND terminal and power terminals using a 500V dc megger
Dielectric strength (AC models):	1500 V, 1 min. between case or GND terminal and power terminals
Dielectric strength (DC models):	500 V, 1 min. between case or GND terminal and power terminals
Power consumption (AC models):	18 VA max. (at operating conditions)
Power consumption (DC models):	7.5 W max. (at operating conditions)
Mass:	SDC20 Approx. 400 g, SDC21 Approx. 500 g
Mounting:	Panel-mount
Terminal screw:	M3.5 self-up screw
Attachment:	Mounting brackets, product manual, industrial unit seal
Mask color:	Dark gray
Case color:	Light gray
Startup time after power ON:	7 s or less
Terminal screw tightening torque:	0.78 to 0.98 N•m
Power interruption dead time:	20 ms min.
Applicable standards:	EN61010-1, EN50081-2, EN50082-2, EN61326
Installation category:	II (IEC664-1, EN61010-1)
Pollution degree:	2

# Chapter 9 MAINTENANCE

---

- Cleaning: Clean the instrument with a soft, dry cloth when it becomes dirty.
- Replacing Parts: Only authorized personnel are allowed to replace parts.
- Replacing Fuses: In case of AC power supply models, when replacing fuses provided on the power supply circuit, use only standard parts specified below.

Standard	IEC127
Type	Time-lag (T)
Voltage rating	250 V
Current rating	0.5 A

This page left intentionally blank

---

# **APPENDICES**

---

**Setup Table**

**Parameters Table**

**Input Ranges Table**

**Alarm Table**

**SDC 20/21 Setting Work Sheets**

**Description of Terms and Abbreviations**

Setup Table

Indication	Setup Item	Setting condition	Initial value	Setting range	Reference page
C01	Key lock	—	0	0: No key lock 1: Key lock	4-5
C02	Temperature unit	T/C or RTD	0	0: Centigrade 1: Fahrenheit	4-5
C03	Control action		0	0: Reverse action 1: Direct action	4-5
C04	Type of input range	—	46	See the input range table.	4-6
C05	Decimal point position	Setting time with temperature range	0	T/C, RTD: 0 to 1 Linear: 0 to 3	4-8
C06	PV range low-limit	—	Lower-limit of range Linear: 0	Lower-limit of range to C07 -0999 to C07	4-8
C07	Upper-limit of PV range	—	Upper-limit of range Linear: 1000	C06 to upper-limit of range C06 to 9999	4-8
C08	SP setting system	—	0	0: Single SP 1: Multi SP	4-8
C09	Lower-limit of SP	—	Lower-limit of range	Lower-limit of range to C10 set value	4-9
C10	Upper-limit of SP	—	Upper-limit of range	C09 to upper-limit range set value	4-9
C11	Selection of output in case of PV abnormal and when READY mode.	—	0	0: PID operation 1: C12 set value	4-9
C12	Selection of output in case of PV over-range	—	Normally 0%	0 to 100%	4-9
C13	Time proportional cycle	TP output type	10	Relay output: 5 to 120 s Voltage output: 1 to 120 s	4-9
C15	Initial manipulated variable in PID operation	—	Normally 0%	0 to 100%	4-9
C16	PID operation initialize	—	0	0: AUTO 1: Initialize in SP change 2: Continuous PID	4-10

Indication	Setup Item	Setting condition	Initial value	Setting range	Reference page
C18	Control system selection	—	0	0: Normal PID control 1: Overshoot relaxation 2: Learning function status 3: Fixed learning status	4-10
C21	Type of auxiliary output	AUX is provided	0	0: PV            1: SP 2: MV	4-12
C23	Green belt	—	5	0 to 1/2 PV range	4-12
C24	Event 1 type	EV1 is provided	0	For details, see the event codes table. 0: Event OFF	4-13
C25	Event 2 type	EV2 is provided	0		
C26	Event 3 type	EV3 is provided	0		
C27	Remote switch function	A remote switch is provided	0	0: NOP 1: READY 2: SP selection 3: Timer drive	4-16
C31	Communication address	Communication option	0	0 to 127	4-17
C32	Transmission speed		0	0: 9600        1: 4800 2: 2400        3: 1200	4-17
C33	Communication code		0	0: 8 bits EP 1 SP 1: 8 bits NP 2 SP	4-17
C35	SP ramp up gradient	—	0	0 to 9999 unit/min.	4-17
C36	SP ramp down gradient	—	0		
C39	Zener barrier adjustment	Zener barrier model C4 = RTD range	0	-20.00 to +20.00	4-18
C40	For factory adjustment				

Note 1: All codes other than specified in this table are used for factory adjustment.

Note 2: Non-corresponding items are skipped.

Note 3: After C40, C1 follows.

Note 4: Codes marked ↓ can be used as initial values.

Parameters Table

No.	Item	Indication	Setting condition	Initial value	Setting range	Remarks
①	Auto tuning start/stop	<i>RT</i>	—	0	0: Execution stops 1: Execution starts	
②	Proportional band	<i>P</i>	—	5.0	0.0 to 999.9%	Applied to models 0D and 6D.
					0.1 to 999.9%	Applied to model 5G.
③	Integral time	<i>I</i>	P ≠ 0	120	0 to 3600 s	
④	Derivative time	<i>d</i>	P ≠ 0	30	0 to 1200 s	
⑤	Lower-limit of manipulated variable	<i>oL</i>	P ≠ 0	0	0 to upper-limit %	
⑥	Upper-limit of manipulated variable	<i>oH</i>	P ≠ 0	100	Lower-limit to 100%	
⑦	Manual reset	<i>rE</i>	I = 0 & P ≠ 0	50	0 to 100%	
	Differential	<i>diFF</i>	P ≠ 0	5	1 to 100 unit	
⑧	PID2	A number is added to the above number.	C8 = 1 With Multi SP	Same as specified above.	Same as specified above.	Note
⑨	Set point 0	<i>SP 0</i>	C8 = 1 With Multi SP	0	Depends upon SP limits (C9, C10).	
	Set point 1	<i>SP 1</i>				
⑩	EV1 hysteresis	<i>HY51</i>	Option EV1 is provided	5	0 to 100 unit	Can not be set in alarm event or timer event modes.
⑪	EV2 hysteresis	<i>HY52</i>	Option EV2 is provided			
⑫	EV3 hysteresis	<i>HY53</i>	Option EV3 is provided			
⑬	PV bias	<i>PbIA</i>	—	0	±1000 unit	

Note 1: In ⑧ PID1, ② to ⑦ are repeated by adding this number. (P2, I2, d2, oL2, rE2/diFF2)

Note 2: After ⑬, ① follows.

Note 3: If an item is not set or it has no function, it is not indicated.

Input Ranges Table

No.	Type	°C range	°F range
01	K	0 to 1200	0 to 2200
02		0.0 to 800.0	0 to 1400
03		-200.0 to +400.0*	-300 to +700
04	J	0 to 1200	0 to 2000
05		0.0 to 800.0	0 to 1400
06		-200.0 to +400.0*	-300 to +700
07	E	0.0 to 800.0	0 to 1400
08	T	-200.0 to +400.0*	-300 to +700
09	R	0 to 1600	0 to 3000
10	S	0 to 1600	0 to 3000
11	B	0 to 1800	0 to 3200
12	N	0 to 1300	32 to 2372
13	PLII	0 to 1300	32 to 2372
14	Wre5-26	0 to 2300	0 to 4000
16	Ni-Mo	0 to 1300	32 to 2372
17	DIN U	-200.0 to +400.0*	-300 to +700
18	DIN L	0.0 to 800.0	0 to 1400
20	JIS	-200.0 to +500.0*	-300 to +700
21	Pt 100	-100.0 to +200.0	-150.0 to +400.0
30	JIS	-200.0 to +500.0*	-300 to +700
31	Jpt 100	-100.0 to +200.0	-150.0 to +400.0
40	4 to 20 mA		Scaling and decimal point position are variable within a range of -1999 to +9999.
41	0 to 20 mA		
45	1 to 5V		
46	0 to 5V		
50	0 to 10 mV		
51	0 to 100 mV		
52	-10 to +10 mV		

\* Although -200.0 cannot be indicated, the action is normal.

Alarm Table

Indication	Problem description	Measures
<b>AL01</b>	PV input exceeds +10% of the range (Over-range).	Check the sensor and wiring. Check the PV range.
<b>AL02</b>	PV input is less than -10% of the range (Under-range).	Check the sensor and wiring. Check the PV range.
<b>AL03</b>	C line input error during resistance thermometer input. CJ input error during thermometer input.	Check C line wiring. Contact a YH service person for repair.
<b>AL70</b>	A/D converter trouble	Contact a YH service person for repair.
<b>AL91</b>	Loader communication message is not correct.	Check cable connection.
<b>AL96</b>	Internal communication parameter error.	Reset by communication or key input operation.
<b>AL97</b>	Parameter error	Reset.
<b>AL98</b>	Adjusting data error	Reset.

---

**SDC 20/21 Setting Work Sheets**

Name of user	Model No.	

## Setup

No.	Indication Set value at delivery time	Setup item Setting range	Set value by user
1	C01 0	Key lock 0: No key lock 1: Key lock	
2	C02 0	Temperature unit 0: °C 1: °F	
3	C03 0	Control action 0: Reverse action 1: Direct action	
4	C04 0	PV input range See the input range table.	
5	C05 0	Decimal point position 0: With no decimal point 1: 1 decimal digit is indicated 2: 2 decimal digits are indicated 3: 3 decimal digits are indicated	
6	C06 Lower-limit of range Linear: 0	Lower-limit of PV input range to C07 Lower-limit of PV input range -1999 to C07	
7	C07 Upper-limit of PV input range Linear: 1000	Upper-limit of PV input range C06 to Upper-limit of PV input range C06 to 9999	
8	C08 0	SP setting system 0: Single SP 1: Multi SP	
9	C09 Lower-limit of range	Lower-limit of SP Lower-limit of range to C10 set value	
10	C10 Upper-limit of range	Upper-limit of SP C09 set value to upper-limit of range	

Prepared by	
Preparation date	

No.	Indication Set value at delivery time	Setup item Setting range	Set value by user
11	C11 0	Selection of output in case of PV over-range 0: PID operation 1: C12 set value	
12	C12 0	Output in case of PV abnormal and when READY mode. 0 to 100%	
13	C13 0	Time proportional cycle Relay output 5 to 120 s Voltage output 1 to 120 s	
15	C15 0	Initial manipulated variable in PID operation 0 to 100%	
16	C16 0	PID operation initialize 0: AUTO 1: Initialize in SP change 2: Continuous PID	
18	C18 0	Control system selection 0: Normal PID control 1: Overshoot relaxation 2: Learning function status 3: Fixed learning status	
21	C21 0	Type of auxiliary output 0: PV 1: SP 2: MV (Manipulated Variable)	
23	C23 0	Green belt 0 to 1/2 PV range	
24	C24 0	Event 1 type See the event codes table	
25	C25 0	Event 2 type See the event codes table	

Prepared by	
Preparation date	

No.	Indication Set value at delivery time	Setup item Setting range	Set value by user
26	<b>C26</b> 0	Event 3 type See the event codes table	
27	<b>C27</b> 0	Remote switch function 0: NOP 1: READY 2: SP selection 3: Timer event drive	
31	<b>C31</b> 0	Communication address 0 to 127	
32	<b>C32</b> 0	Transmission speed 0: 9600 bps 1: 4800 bps 2: 2400 bps 3: 1200 bps	
33	<b>C33</b> 0	Communication code 0: 8 bits 1 stop bit even parity 1: 8 bits 2 stop bits no parity	
35	<b>C35</b> 0	SP ramp up gradient 0 to 9999 unit/min.	
36	<b>C36</b> 0	SP ramp down gradient 0 to 9999 unit/min.	
39	<b>C39</b> 0	Zener barrier adjustment -20.00 to +20.00	

Prepared by	
Preparation date	

Parameter Table

No.	Indication Set value at delivery time	Setup item Setting range	Set value by user
1	<i>RT</i> 0	Auto tuning start/stop 0: Execution stops 1: Execution starts	
2	<i>P</i> 5.0	Proportional band 0D, 6D 0.0 to 999.9% 5G 0.1 to 999.9%	
3	<i>I</i> 120	Integral time 0 to 3600 s	
4	<i>D</i> 30	Derivative time 0 to 1200 s	
5	<i>oL</i>	Lower-limit of manipulated variable 0 to upper-limit %	
6	<i>oH</i> 100	Upper-limit of manipulated variable Lower-limit to 100%	
7	<i>rE</i> 50	Manual reset 0 to 100%	
8	<i>DIFF</i> 5	Differential 1 to 100%	
9	<i>P I</i> 5.0	Proportional band 0D, 6D 0.0 to 999.9% 5G 0.1 to 999.9%	
10	<i>I I</i> 120	Integral time 0 to 3600 s	

Prepared by	
Preparation date	

No.	Indication Set value at delivery time	Setup item Setting range	Set value by user
11	<i>d I</i> 30	Derivative time 0 to 1200 s	
12	<i>o L I</i> 0	Lower-limit of manipulated variable 0 to upper-limit %	
13	<i>o H I</i> 100	Upper-limit of manipulated variable Lower-limit to 100%	
14	<i>r E I</i> 50	Mnual reset 0 to 100%	
15	<i>d I F F I</i> 5	Differential 1 to 100%	
16	<i>S P - 0</i> 0	Set point 0	
17	<i>S P - 1</i> 0	Set point 1	
18	<i>H Y S 1</i> 5	EV1 hysteresis 0 to 100 unit	
19	<i>H Y S 2</i> 5	EV2 hysteresis 0 to 100 unit	
20	<i>H Y S 3</i> 5	EV3 hysteresis 0 to 100 unit	
21	<i>P b i A</i> 0	PV bias 0 to 100 unit	

**Description on Terms and Abbreviations**

<b>AT:</b>	Auto tuning. The numerics of PID are automatically adjusted optimum values.
<b>DISP:</b>	Display. The indicated contents of the indicators are changed by pressing the DISP key.
<b>EV:</b>	Event. On-off signals are sent according to control condition.
<b>OL:</b>	Output Low. Lower input of output. A minimum limit value of output is set.
<b>OH:</b>	Output High. Upper limit of output. A maximum limit value of output is set.
<b>OUT:</b>	Output. Control output.
<b>PARA:</b>	Parameter. Variable which determines the operating conditions of this instrument.
<b>PID:</b>	P (Proportioning) .... Proportional action I (Integral) ..... Integral action or reset action D (Derivative) ..... Derivative action or rate action
<b>PV:</b>	Process value. Measured value of thermocouple, resistance thermometer bulb, or linear input, etc.
<b>Setup:</b>	To set the operating conditions of this instrument such as an input range or control action according to how to use an associated equipment.
<b>Differential:</b>	Differential gap in on/off control action. A differential value between control output on point and off point. This prevents the control output from turning on/off on a short cycle when a PV becomes equal to an SP.
<b>Hysteresis:</b>	Operation width in event action. A differential value between the event on and off points.



**YAMATAKE**

*Specifications are subject to change without notice.*

**Yamatake Corporation**  
**Advanced Automation Company**  
**International Business Headquarters**

Totate International Building

2-12-19 Shibuya Shibuya-ku

Tokyo 150-8316 Japan

URL: <http://www.yamatake.com>

*This has been printed on recycled paper.* (01)

Printed in Japan.

1st Edition: Issued in Aug., 1993

10th Edition: Issued in Nov., 2003(B)